

DRS4 Evaluation Board User's Manual

Board Revision 5
as of January 2014

Last revised: May 2, 2016



Stefan Ritt
Paul Scherrer Institute
CH-5232 Villigen PSI
Switzerland

Email: stefan.ritt@psi.ch

Phone: +41 56 310 3728

Revision History

Date	Modification
2 March 09	Initial Revision
27 April 09	Mention input range, added timing calibration description
3 Aug. 09	Added LED description
12 July 10	Updated documentation for evaluation board V3
12 Sept. 10	Added maximum input voltage
16. Feb. 12	Added info for external connectors
5. Dec. 12	Changed LED description, added OSX part
11. Jan 13	Changed binary format for multi-board functionality
18. Dec. 13	Updated documentation for evaluation board V5
28. Feb. 14	Added note on clock distribution
6. Mar. 14	Added formulas for inter-channel time alignment
26. Sept. 14	Added range in binary format
2. May 16	Changed binary format to contain scalers

Table of Contents

Revision History	2
Table of Contents	3
1. Introduction	4
1.1. Board description	4
1.2. LEDs.....	6
1.3. Firmware Description.....	7
2. Installation.....	9
2.1. Windows XP	9
2.2. Windows 7.....	12
2.3. Linux	14
2.4. Macintosh OSX.....	16
3. Running the Board	17
3.1. Command line Interface “drsc1”.....	17
3.2. Oscilloscope application “DRSOsc”	18
3.3. Multi-board configuration	26
4. Development Hints.....	27
4.1. Power Supply	27
4.2. Analog Input.....	28
4.3. Control Voltages	29
4.4. ADC Clock.....	29
4.5. Calibration.....	29
5. DRS4 Evaluation Board V5 Schematics.....	30
6. DRS4 Evaluation Board V5 Bill of Materials.....	37

1. Introduction

The DRS4 chip, which has been designed at the Paul Scherrer Institute, Switzerland by Stefan Ritt and Roberto Dinapoli is a Switched Capacitor Array (SCA) capable of digitizing eight channels at sampling speeds up to 5 GSPS and 1024 sampling points. This chip is available through the PSI technology transfer program for other institutes and organizations. In order to simplify the design process to integrate the DRS4 chip into custom electronics, an evaluation board has been designed, which demonstrates the basic operation of the chip. It has SMA connectors for four input channels CH1 to CH4, an USB 2.0 connector and MMCX connectors for triggering and clock synchronization (Figure 1). The board is powered through the USB port and contains an on-board trigger logic. It comes with MS Windows[®], Linux and Mac OSX drivers and two application programs. It is basically equivalent to a four channel 5 GSPS digital oscilloscope.

This manual describes the software installation, the usage of the application programs, and gives hints for developers seeking to build new electronics around the DRS4 chip.

1.1. Board description

Since the DRS4 chip has differential inputs, the board uses four active buffers (THS4508 from Texas Instruments[®]) to convert the 50-Ohm terminated single ended inputs into differential signals. Analog switches in front of the buffers (ADG901 from Analog Devices[®]) are used to de-couple the inputs during calibration. Two reference voltages are generated by the on-board 16-bit DAC to measure the offset and gain of all DRS4 storage cells for calibration. The four analog inputs are AC coupled and have a input range of 1 V peak-to-peak. The DRS4 is read out with a 14-bit ADC (AD9245 from Analog Devices[®]) and a FPGA (Xilinx[®] Spartan 3). The USB connection is implemented with a micro controller (Cypress[®] CY2C68013A). The high speed modulus of the USB 2.0 bus allows for data transfer rates of more than 20 MB/sec.

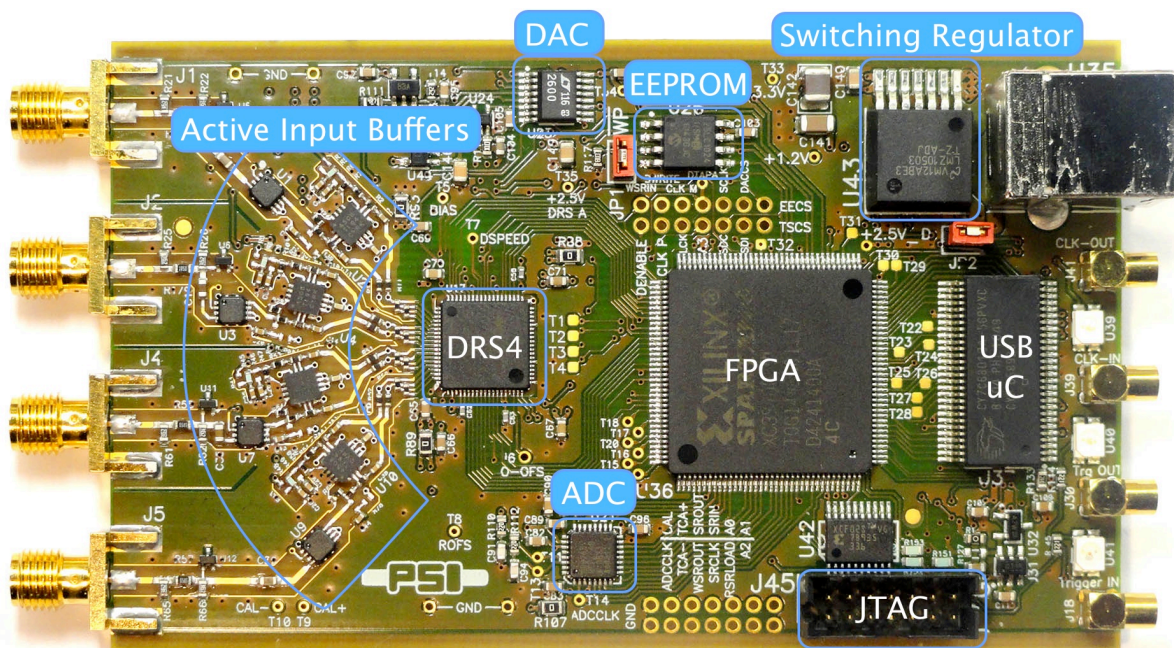

Figure 1: Picture of the DRS4 Evaluation Board V5 with different components

For trigger purposes and inter-board synchronization, four MCX connectors are available, which can be seen on the right side of Figure 1. The **Trigger IN** works as an external trigger much like the one of an oscilloscope. The electrical standard is 5V TTL. Although a 50 Ω termination is possible, the resistor is not soldered by default. This allows using weaker sources, which cannot drive 5V into a 50 Ω load. Reflections on this line usually do not matter, since the first leading edge of the trigger is used. To connect a SMA cable to the trigger input, a commercial adapter can be used like the one shown in.



Figure 2: MCX-SMA adapter which can be obtained for example from www.digikey.com (part number ACX1348-ND)

The **Trigger OUT** signal sends a 150 ns wide pulse when ever the board triggers via the internal hardware trigger. It does not output a trigger when the board is triggered via software (for example in the “AUTO” trigger mode of the DRSc program). The signal standard is 5V TTL. When terminated with 50 Ω, the signal amplitude will only reach about 2V. As written above, in most cases the termination should not be necessary.

The **Clock IN/OUT** signals will be supported in a future firmware version to allow a better synchronization between different boards for multi-board DAQ systems.

Four on-board discriminators with programmable level allows for self triggering on any of the four input channels, or a combination of channels supporting coincidences for example. A 1 MBit EEPROM (25LC1025 from Microchip®) is used to store the board serial number and calibration information. Two 14-pin headers carry all important logical signals which allow easy debugging with a logic analyzer or oscilloscope. A JTAG adapter can be used to update the FPGA firmware through a Xilinx® Platform Cable Adapter.

The specifications of the board inputs is summarized in following table:

Analog inputs Termination Input range Maximum allowed input voltage DC Long pulse (<2μs) Short pulse (<200ns)	50 Ω 1 V p-p ± 10V ± 20V ± 30V	AC coupled
Trigger input/Clock input Termination Maximum allowed input voltage High Level Input Voltage	high impedance, optionally 50 Ω -0.5 V to +5.5 V 2.5 V (min)	5 V TTL compatible
Trigger output/Clock output Level	5V TTL	

1.2. LEDs

The DRS4 evaluation board is equipped with three LEDs. They are operated by the micro controller and the FPGA and have following meaning:

LED	Meaning
Blue	This LED becomes green when the on-board micro-controller booted successfully. If this LED stays dark, there is either no power or the micro-controller lost its program, which requires a re-programming of the EEPROM.
Green	When the on-board FPGA boots correctly this LED becomes lit. If it stays dark, it might be that the FPGA program was lost and requires re-programming. After booting, this LED indicates the board status. If lit, the DRS4 chip is active and sampling data. If stopped by software or a trigger, this LED turns off. A special pulse stretcher ensures that even in high trigger rate environments this LED does not flash with more than ~10Hz so the blinking can still be seen by eye.
Yellow	When lit, this LED indicates a error condition

1.3. *Firmware Description*

Both the Windows and the Linux distribution contain a subdirectory “firmware” which contains the FPGA and Microcontroller firmware for the DRS4 Evaluation Board. The FPGA firmware is written in pure VHDL, thus making it easy to port it to other FPGA devices such as Altera® or Lattice®. Only a few Xilinx® basic components such as clock managers and I/O blocks have been instantiated and must be adapted when another FPGA manufacturer than Xilinx® is chosen. The FPGA source code is contained in several files with following contents:

src/drs4_eval1.vhd	Top level entity. Routing of clock signals, global reset signal, LEDs and LEMO input
src/drs4_eval1_app.vhd	Main file containing state machines for DRS4 readout, serial interface to DAC, EEPROM and temperature sensor, trigger logic and reference clock generation
src/usb_dpram.vhd	Instantiates block ram for waveform storage
src/usb_racc.vhd	Interface to CY2C68013A microcontroller in slave FIFO mode. Implements a set of status and control registers through which the main application can be controlled
src/usr_clocks.vhd	Generates 66 MHz, 132 MHz, 264 MHz and a phase shifted 66 MHz clock out of the 33 MHz quartz input frequency via the Xilinx® Digital Clock Managers (DCM)
ucf/drs4_eval1.ucf	Constraint file. Assigns package pins and defines clock constraints
3s400/drs4_eval1.ise	Xilinx® ISE 9.2i project file
3s400/drs4_eval1.bit	Compiled firmware image directly for Spartan 3s400 FPGA
3s400/drs4_eval1.mcs	Compiled firmware image for FPGA EEPROM XCF02S
3s400/drs4_eval1.ipf	Xilinx® Impact project file to program FPGA via download cable

The firmware for the USB microcontroller from Cypress® is written in C and must be compiled with the Keil® 8051 C compiler. It contains the standard include and library files from the Cypress EZ-USB® development kit plus some DRS specific files:

CY7C68013A/drs_eval.c	Main micro controller firmware file
CY7C68013A/dscr.a51	USB descriptor tables
CY7C68013A/drs_eval.hex	Compiled firmware file (Intel HEX format)
CY7C68013A/drs_eval1.iic	Compiled firmware file (For Cypress EZ-USB Console download)
CY7C68014A/*	Remaining files are standard files from EZ-USB development kit

DRS4 Evaluation Board User's Manual

The FPGA firmware implements a set of control and status registers, through which the DRS4 can be controlled and read out. The mapping of the control registers is as follows:

#	Ofs.	Bit	Name	Comment
0	0x00	0	start_trig	Write a "1" to start the domino wave
0	0x00	1	reinit_trig	Write a "1" to stop & reset the DRS chip
0	0x00	2	soft_trig	Write a "1" to stop the DRS chip & read the data to RAM
0	0x00	3	eeprom_write_trig	Write contents of RAM into EEPROM (32kB page)
0	0x00	4	eeprom_read_trig	Read contents of EEPROM into RAM (32kB page)
0	0x02	18	led	1=on, 0=blinks once at beginning of DRS chip readout
0	0x02	19	tcal_en	Switch on (1) / off (0) 100 MHz calib. sig. for DRS chips
0	0x02	21	transp_mode	1=send DRS inputs to outputs ("transparent mode")
0	0x02	22	enable_trigger1	Write a "1" to enable external trigger (LEMO)
0	0x02	23	readout_mode	0:start from first bin, 1:start from domino stop
0	0x02	24	neg_trigger	1=trigger on high to low transition
0	0x02	25	acalib	Write "1" to enable amplitude calibration
0	0x02	26	refclk_source	0: FPGA, 1: external MCX CLKIN reference clock
0	0x02	27	dactive	0:stop domino wave during readout, 1:keep it running
0	0x02	28	standby	1: put chip in standby mode
1	0x04	31..16	DAC0	Set DAC 0 (=A, ROFS)
1	0x06	15..0	DAC1	Set DAC 1 (=B, CMOFS)
2	0x08	31..16	DAC2	Set DAC 2 (=C, CAL-)
2	0x0A	15..0	DAC3	Set DAC 3 (=D, CAL+)
3	0x0C	31..16	DAC4	Set DAC 4 (=E, BIAS)
3	0x0E	15..0	DAC5	Set DAC 5 (=F, TLEVEL)
4	0x10	31..16	DAC6	Set DAC 6 (=G, O-OFS)
4	0x12	15..0	DAC7	Set DAC 7 (=H, -)
5	0x14	31..24	configuration	Bit0: DMODE, Bit1: PLEN, Bit2: WSRLOOP
5	0x14	23..16	channel_config	1=1x8k,0x11=2x4k,0x33=4x2k,0xFF=8x1k
5	0x16	15..8	adcclk_phase	ADC clock phase
5	0x16	7..0		
6	0x18	31..16	trigger_delay	Trigger delay in ticks of roughly 2.3 ns
6	0x1A	15..0	sampling_freq	Sampling frequency in ticks ($=1024/f_{\text{samp}} \cdot 0.120-2$)
7	0x1E	31..16	trigger_config	Trigger configuration
7	0x1E	15..0	eeprom_page	Page number for EEPROM communication

While the mapping of the status registers is like this:

#	Ofs.	Bits	Name	Comment
0	0x00	31..16	board_magic	0xC0DE, Magic number for DRS board identification
0	0x02	15..8	board_type	7: Eval. Board V3, 8: Eval. Board V4, 9: Eval Board V5
0	0x02	7..0	drs_type	4 for DRS4
1	0x04	0	running	"1" while domino wave running or readout in progress
2	0x08	31..16	stop_cell	position of cell where sampling stopped at last trigger
8	0x20	31..16	temperature	temperature in 0.0625 deg. C units
9	0x24	31..16	serial_cmc	Board serial number
9	0x26	15..0	version_fw	firmware version (SVN revision)
10	0x28	31..16	scaler_1hi	Scaler for input #1
10	0x2A	15..0	scaler_1lo	
11	0x2C	31..16	scaler_2hi	Scaler for input #2

11	0x2E	15..0	scaler_2lo	
12	0x30	31..16	scaler_1hi	Scaler for input #3
12	0x32	15..0	scaler_1lo	
13	0x34	31..16	scaler_1hi	Scaler for input #4
13	0x36	15..0	scaler_1lo	
14	0x38	31..16	scaler_1hi	Scaler for trigger
14	0x3a	15..0	scaler_1lo	

All registers are implemented as 32-bit registers, so they can be mapped easily into some VME address space for example if one decides to build a VME board containing the DRS4.

2. Installation

2.1. Windows XP

Under MS Windows[®] it is important to install the necessary driver before connection the DRS4 Evaluation Board with the PC. The current distribution can be downloaded from <http://www.psi.ch/drs/download>. The Windows version contains a single program **drs-xx.exe** (where **xx** is the version) which can be executed to install the driver, applications, documentation and source code. Executing this file starts the installer:

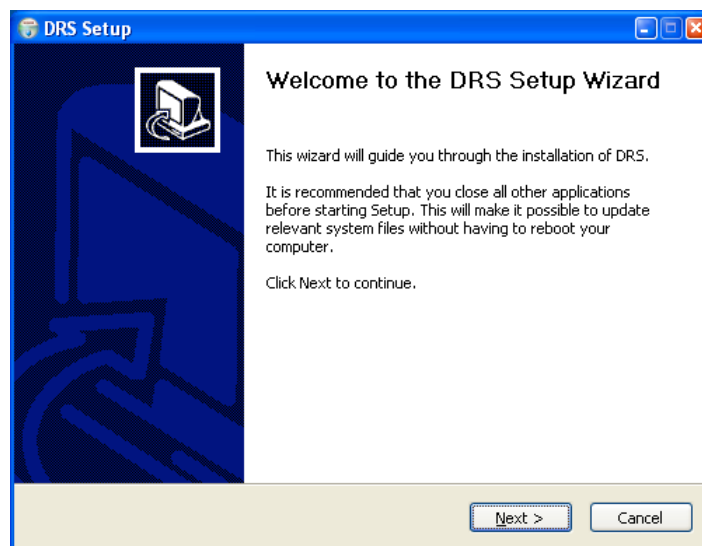

You can select which components to be installed:

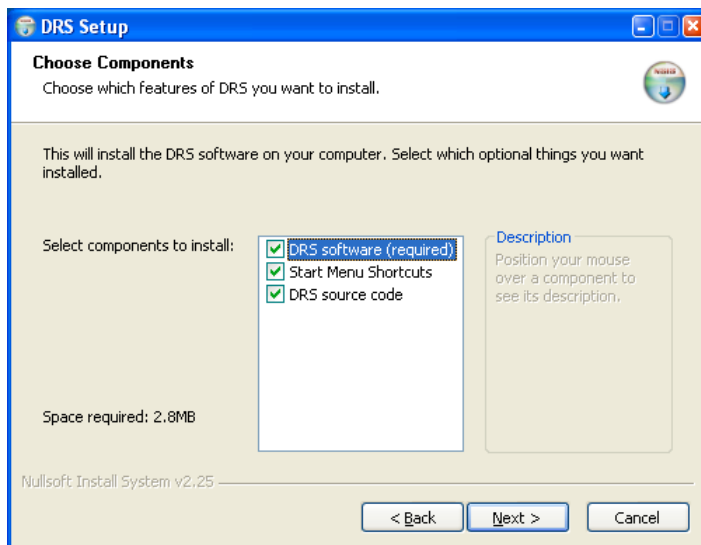

Then you can select the installation directory:

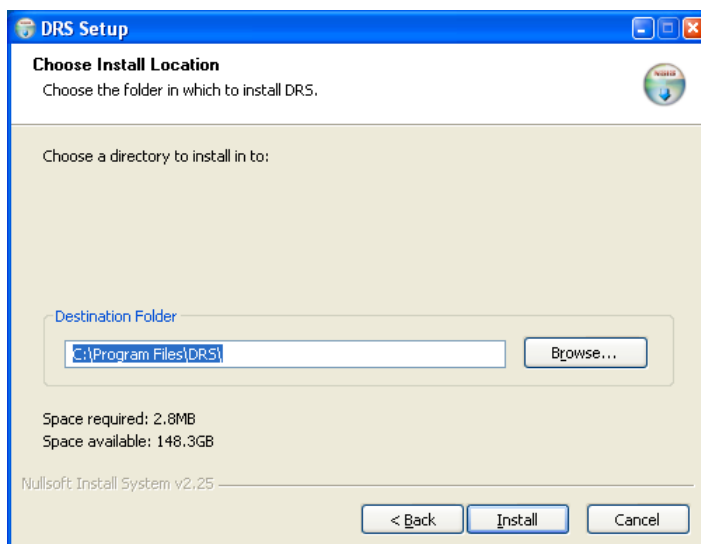

After the installer has finished, you can connect the DRS4 Evaluation Board to the Computer:

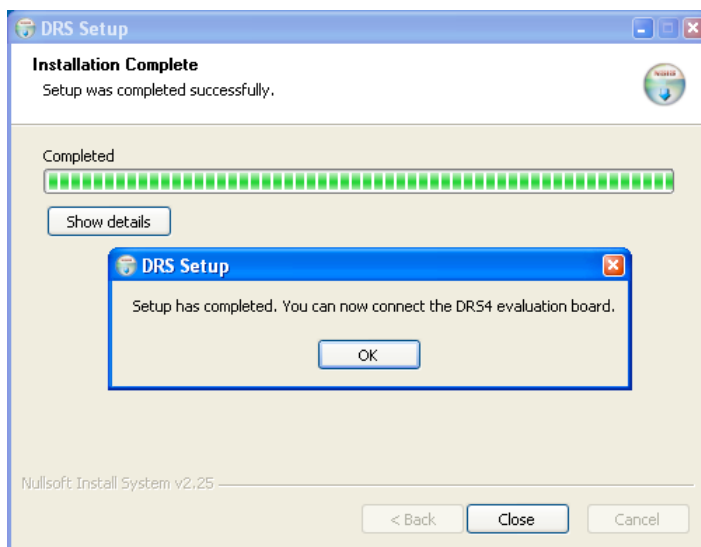

Now you will see the "Found New Hardware" dialog:



Where you can click “Install the software automatically” and then click “Next”.
 After successful installation of the driver, you will see the following window:

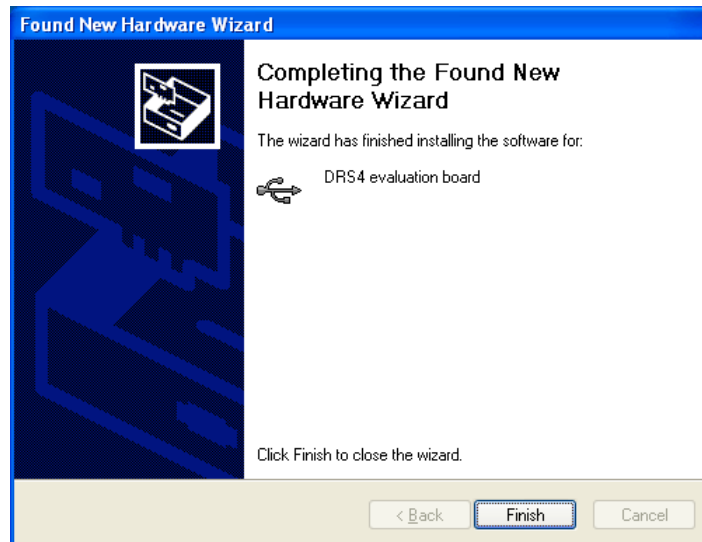

And a new group in your Start Menu:

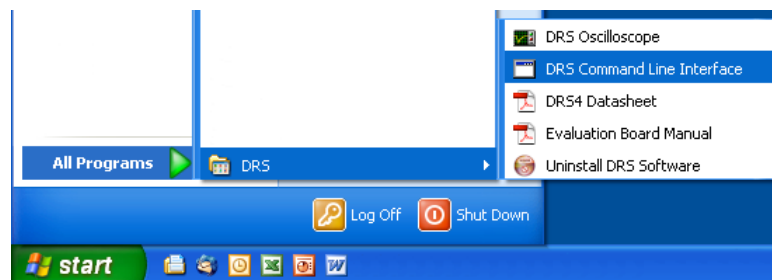

The software comes with two applications, a command line interface and an oscilloscope. These applications are explained in section 0.

2.2. Windows 7

The installation under Windows 7 (32 and 64 bit) is basically the same than for Windows XP. You need the DRS software version 3.0.1 or later if you are using a 64-bit system, since version 3.0.0 and prior does not contain the 64-bit version of the **libusb** library. When you start the software installation, you get an additional screen which you have to confirm:

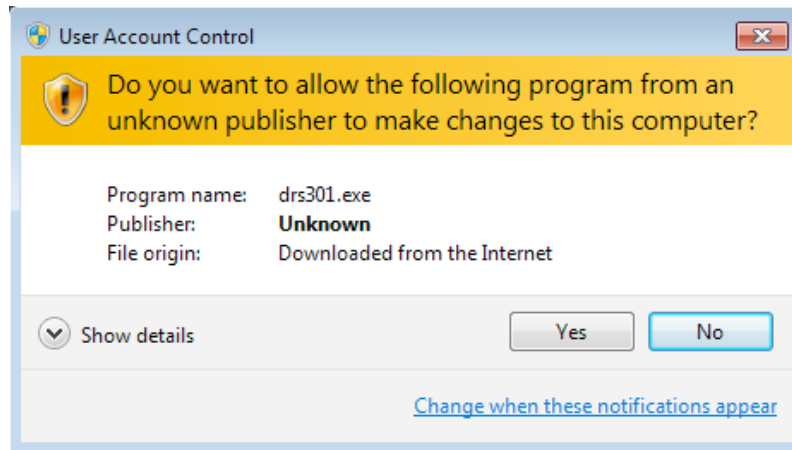

Make sure that you are logged in as an administrator to install the software. During the installation process, you will see a notice about some unverified driver software. Please select *"Install this driver software anyway"* to install the driver.

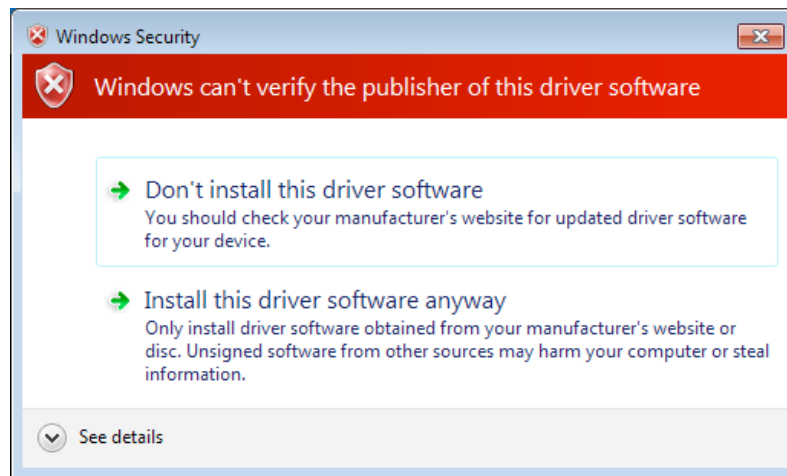

After the software has been installed, you can connect the DRS4 Evaluation Board to the computer. The driver installation should then start automatically and you will see this notification:

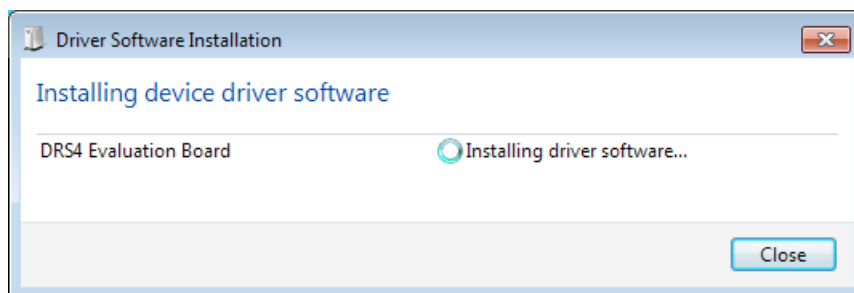

When this has finished, you can start the "drsc1" and "drsosc" programs.

2.3. Upgrading from software

Prior to software version 5.0, a different USB driver has been used. If one wants to install the current version over a pre-5.0 software version, one has to tell Windows to update the USB driver after the 5.0 software has been installed as shown in the previous chapter. This is done via the Device Manager, which can be accessed through Computer Management. If an old driver is installed, there will be an entry “DRS4 evaluation board” under the group “LibUSB-Win32 Devices”. To update the driver, do a right mouse click on the board and select “Update Driver...” from the context menu:

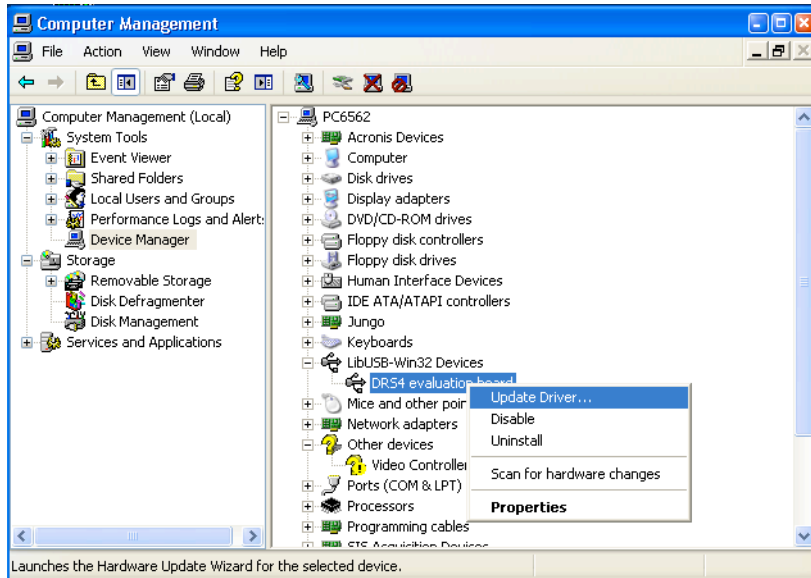

Click “No” on the next page asking to connect to Windows Update, then select “Install the software automatically”:

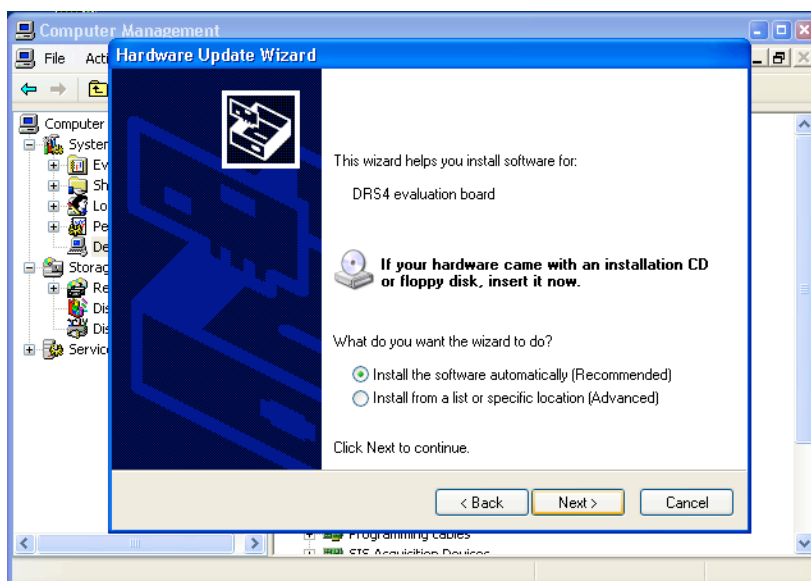

This will update the USB driver for the DRS4 board correctly. The board will now be listed under “libusb (WinUSB) devices” instead of “LibUSB-Win32 Devices”.

2.4. Linux

The drivers and applications are distributed for Linux in source code and must be compiled on each system. First untar the tar ball:

```
[/usr/local]$ tar -xvzf drs-1.0.tar.gz
drs-1.0/
drs-1.0/doc/
drs-1.0/doc/DRS4_rev06.pdf
drs-1.0/doc/manual.pdf
drs-1.0/include/
drs-1.0/include/ConfigDialog.h
drs-1.0/include/DOFrame.h
drs-1.0/include/DOScreen.h
. . .
```

Then change the directory and do a „make“. Note that to compile the oscilloscope application it is necessary to have the wxWidgets package version 2.8.9 or later installed. You can obtain this package in source form from <http://www.wxwidgets.org/downloads/>. If this package is present, you can change to the drs directory and issue a make:

```
[/usr/local]$ cd drs-1.0
[/usr/local/drs-1.0]$ make
g++ -g -O2 -Wall -Wuninitialized -fno-strict-aliasing -Iinclude -DOS_LINUX
-DHAVE_LIBUSB -c src/musbstd.c
g++ -g -O2 -Wall -Wuninitialized -fno-strict-aliasing -Iinclude -DOS_LINUX
-DHAVE_LIBUSB -c src/mxml.c
. . .
```

Now you can connect the DRS4 board to the PC. On systems where the “lsusb” tool is installed, one should be able to find the DRS4 evaluation board after connecting it with following command:

```
[/usr/local/drs-1.0]$ /sbin/lsusb -d 04b4:1175 -v
```

```
Bus 005 Device 005: ID 04b4:1175 Cypress Semiconductor Corp.
```

```
Device Descriptor:
```

```
  bLength                18
  bDescriptorType        1
  bcdUSB                  2.00
  bDeviceClass            0 (Defined at Interface level)
  bDeviceSubClass        0
  bDeviceProtocol        1
  bMaxPacketSize0        64
  idVendor                0x04b4 Cypress Semiconductor Corp.
  idProduct              0x1175
  bcdDevice              0.01
  iManufacturer          1 S. Ritt PSI
  iProduct               2 DRS4 Evaluation Board
  iSerial                3 REV1
```

```
  bNumConfigurations    1
  Configuration Descriptor:
```

```
  bLength                9
  bDescriptorType        2
  wTotalLength           46
  bNumInterfaces         1
  bConfigurationValue    1
  iConfiguration        0
  bmAttributes           0x80
  MaxPower               500mA
```

```
...
```

If the board is correctly recognized, one can access it with the command line program. Under most Linux distributions however, only the “root” user can directly access USB devices. Some systems can be configured to allow non-root access via the “udev” system, but the exact instructions vary from distribution to distribution and can therefore not be given here.

If the command line program works, the oscilloscope application “drsosc” can be started. It will open a X window and show exactly the same functionality as its Windows counterpart:

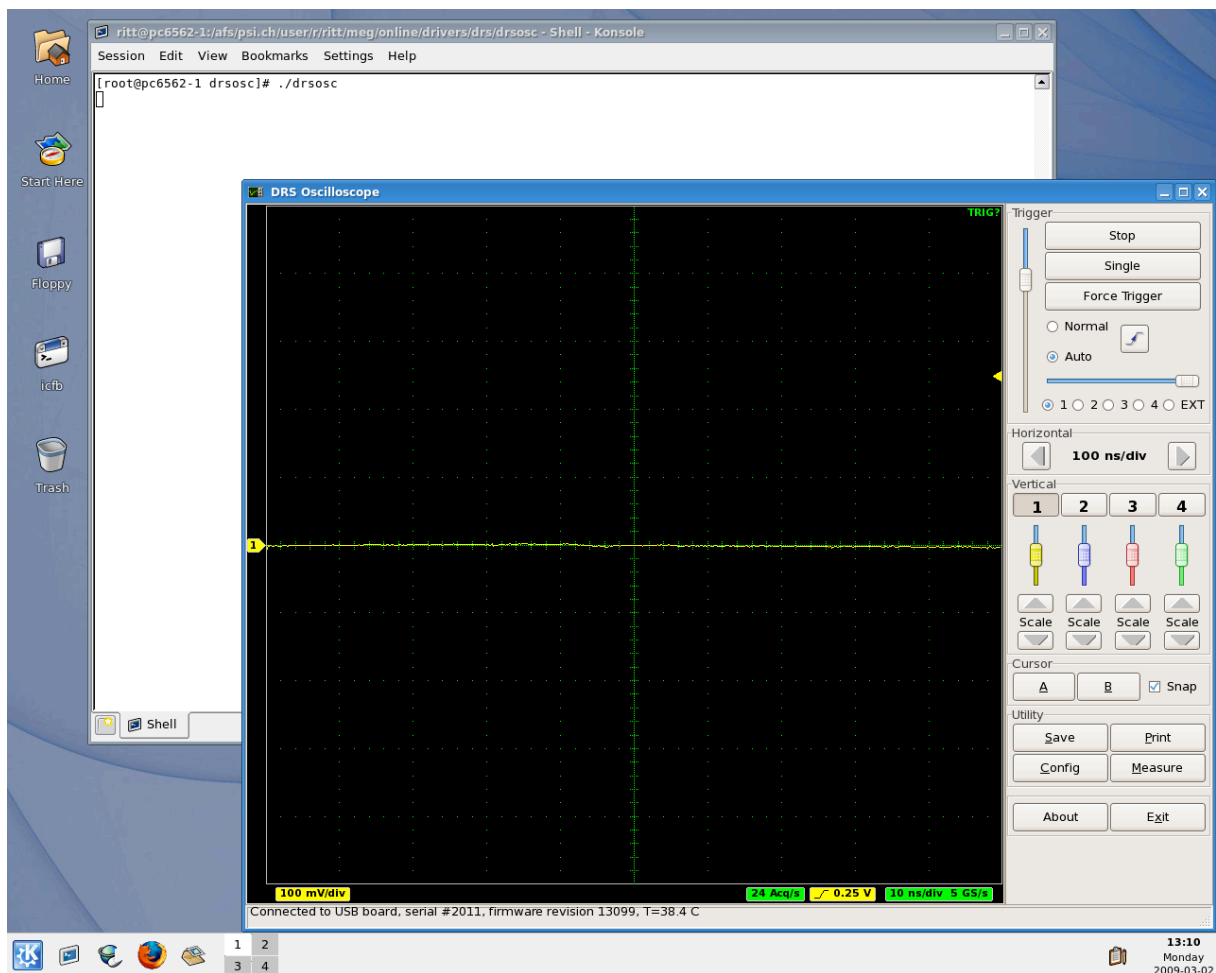

2.5. *Macintosh OSX*

The Linux tar ball is in principle compatible with OSX 10.6+, so a simple “make” will compile the applications. A more convenient way is however to install the pre-compiled binary DRSOsc program. Simply download **DRS Oscilloscope.dmg** from <http://www.psi.ch/drs/download>, click on it and drag the DRSOsc icon into the Application folder. The libusb library is already compiled into the executable so does not need to be installed separately, unless one wants to compile the programs from the tar ball.

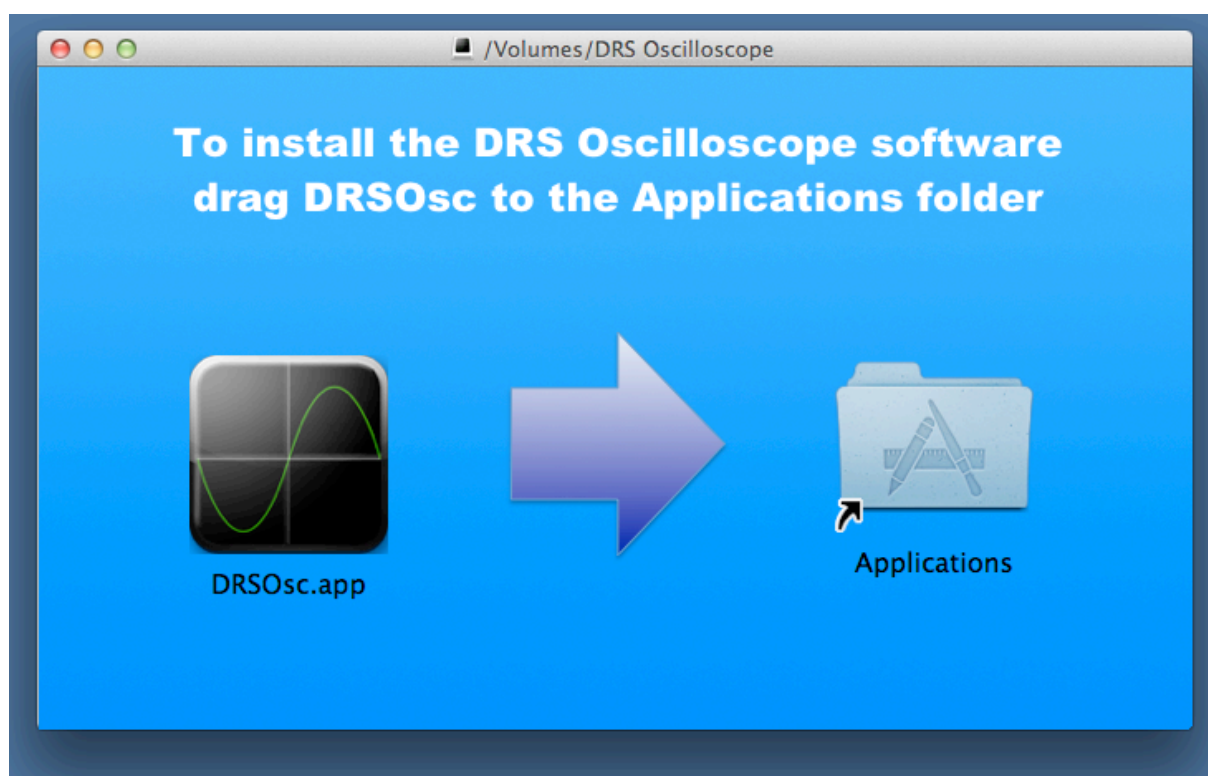

3. Running the Board

3.1. Command line Interface “drsc1”

Clicking on „DRS Command Line Interface“ (Windows) or entering “drsc1” (Linux) will start a simple application which connects to the DRS4 Evaluation Board. If it finds the board, it displays the board serial number and the firmware revision as on the following screen shot:

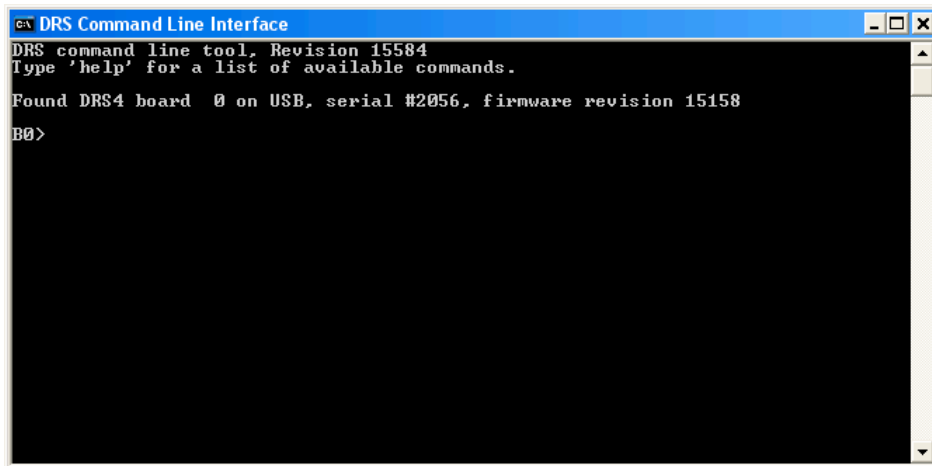

```
DRS Command Line Interface
DRS command line tool, Revision 15584
Type 'help' for a list of available commands.
Found DRS4 board 0 on USB, serial #2056, firmware revision 15158
B0>
```

Now you are ready to issue your first command “info” which shows some more information, like the current board temperature. The temperature sensor is on the bottom side just below the DRS4 chip. If you keep issuing “info” commands and touch that sensor with your finger, you should see the temperature increase.

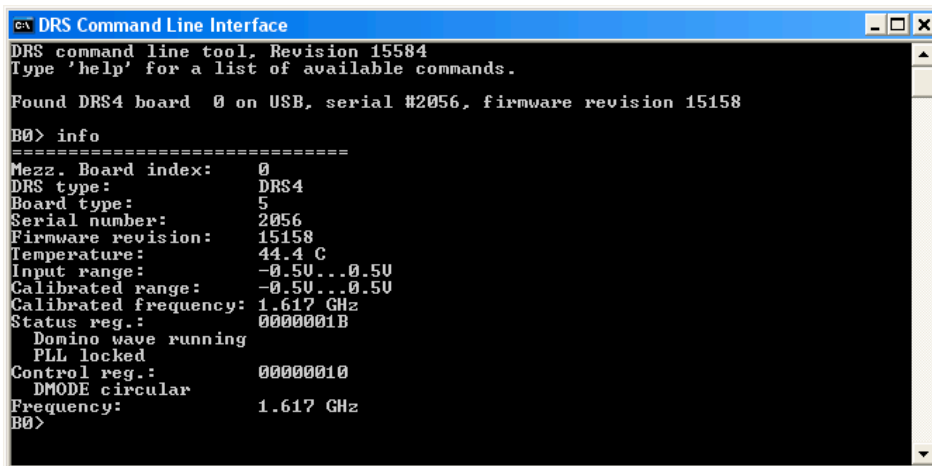

```
DRS Command Line Interface
DRS command line tool, Revision 15584
Type 'help' for a list of available commands.
Found DRS4 board 0 on USB, serial #2056, firmware revision 15158
B0> info
=====
Mezz. Board index: 0
DRS type: DRS4
Board type: 5
Serial number: 2056
Firmware revision: 15158
Temperature: 44.4 C
Input range: -0.50...0.50
Calibrated range: -0.50...0.50
Calibrated frequency: 1.617 GHz
Status reg.: 0000001B
  Domino wave running
  PLL locked
Control reg.: 00000010
  DMODE circular
Frequency: 1.617 GHz
B0>
```

3.2. Oscilloscope application "DRSOsc"

The second application is an oscilloscope-like program, which connects to the DRS4 board and works pretty much like a normal oscilloscope. You can select the trigger mode, trigger level and trigger source, which can also be a logical combination of channels. You enable a channel by clicking on the number "1" to "4". There are two cursors and a few utilities.

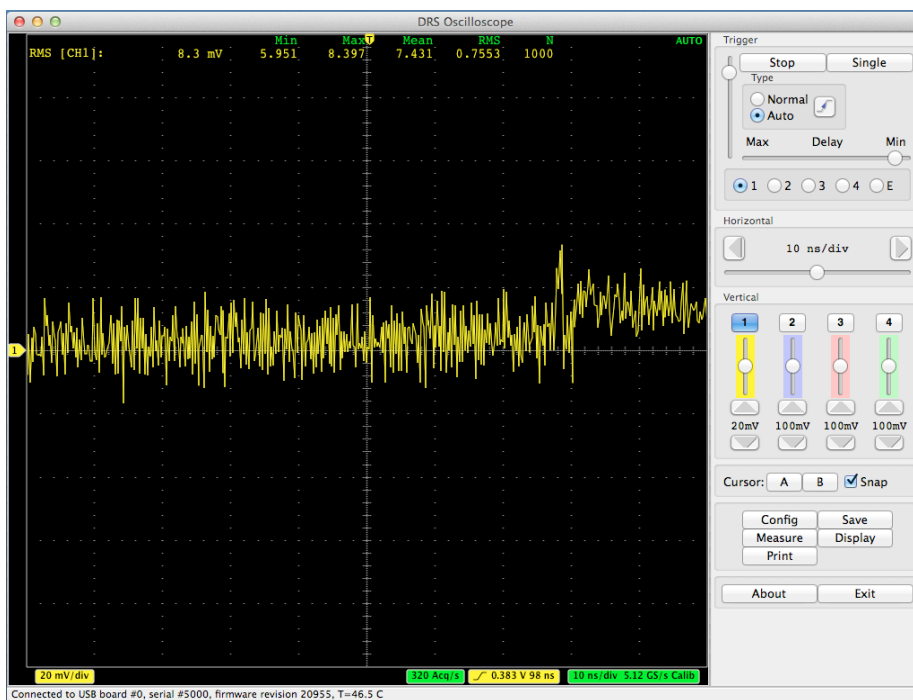

The picture above shows an un-calibrated evaluation board, which shows a noise level of about 8 mV RMS. After offset and gain calibrations, the noise level is reduced significantly to a level of about 0.35 mV:

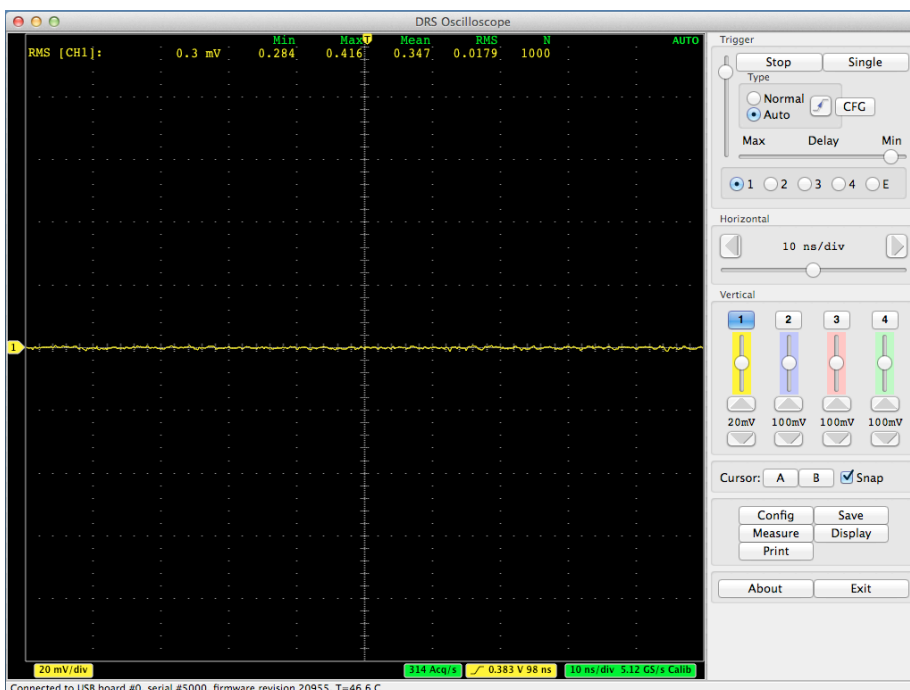

The DRS4 evaluation board is shipped pre-calibrated in amplitude and time. This calibration can be turned on or off using the check boxes “Display calibrated waveforms” and “Display timing calibrated waveforms” in the “Config” Dialog:

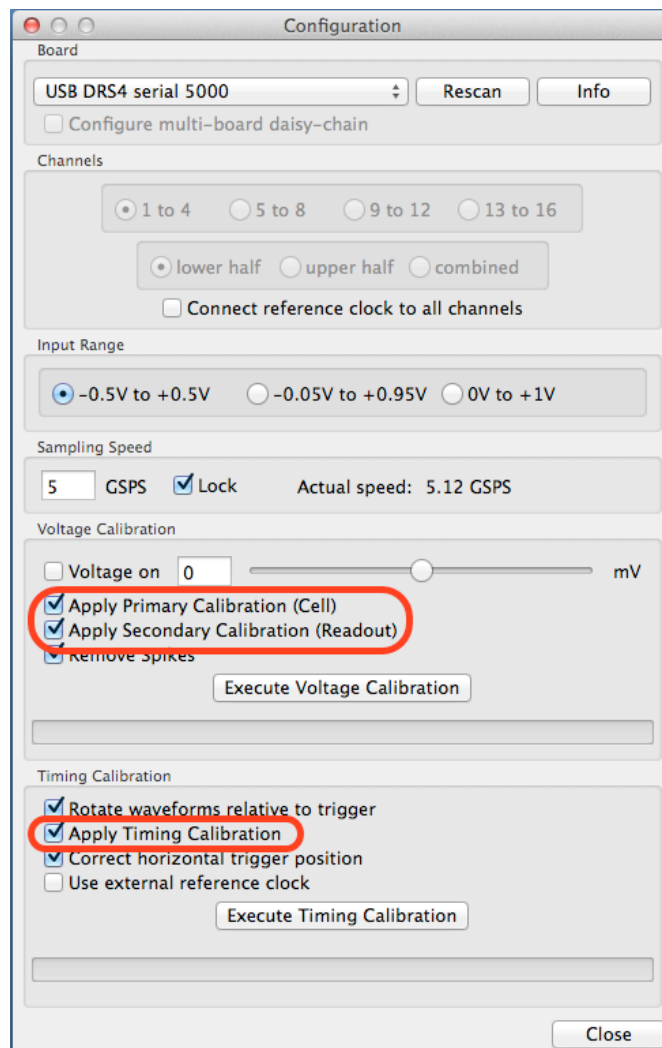

The calibration can be re-done any time by clicking on the “Execute Voltage Calibration” and “Execute Timing Calibration” buttons. For the voltage calibration, the inputs are switched to a calibration voltage generated by a DAC. Three calibration points (-0.4V, 0V, +0.4V) are measured and an offset and gain is evaluated. For the timing calibration, an internal 100 MHz clock is sampled in all channels and analyzed to determine the effective width of each cell. Following picture shows the result of such a timing calibration done at 5 GSPS. The effective bin width deviates from the nominal value of 0.2 ns by up to ± 100 ps, and the integral timing nonlinearity adds up to almost 0.4 ns, which is typical for the DRS4 chip. Since transistor parameters have normally gradients over the chip wafer, SCA chips are usually “faster” on one side than on the other.

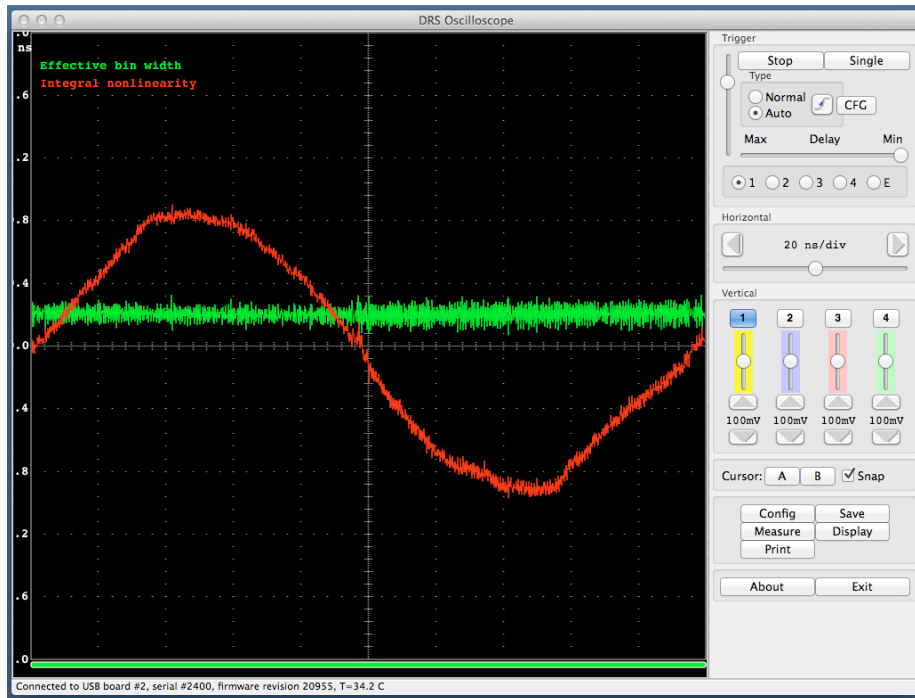

This calibration data both for voltage and timing is then stored in the EEPROM on the evaluation board, from where it is obtained each time the oscilloscope gets started. This assures that a board is calibrated even when used on different computers. Note however that the timing calibration is only valid for one individual sampling speed. So if you want to run the board at a different speed, you have to redo the timing calibration at that speed. The voltage calibration is a bit less dependent on the sampling speed, there is however some dependence on temperature. It is advised to keep the board running for a few minutes until the temperature shown in the status bar stabilizes before doing a voltage calibration. If you want to achieve the ultimate timing resolution, a voltage calibration has to be done before each timing calibration. The evaluation board is then capable of measuring time differences down to a few pico seconds:

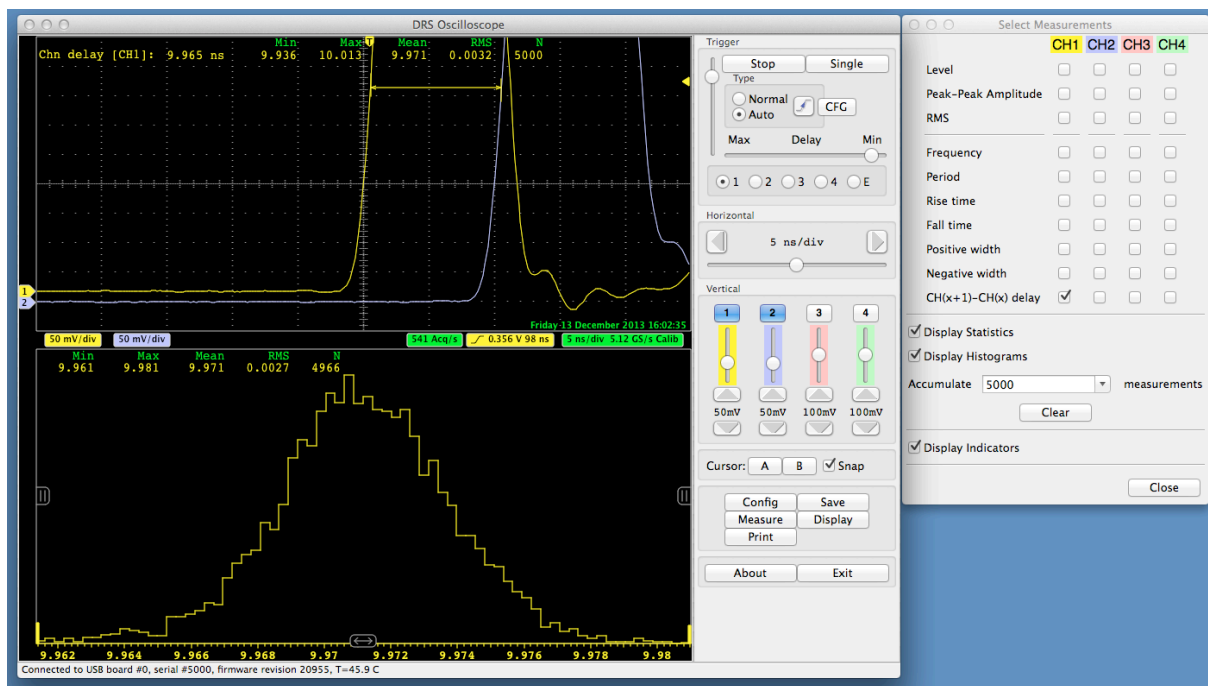

For test purposes, an internal 100 MHz reference clock signal can be connected to all channels via the “Config” menu:

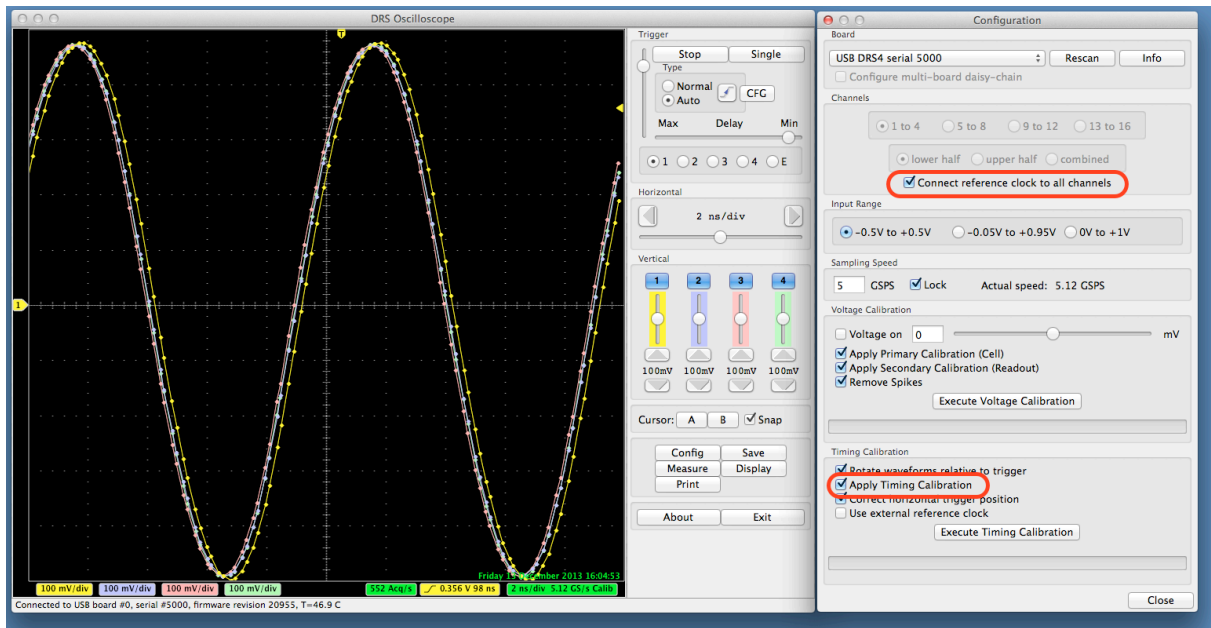

The effect of the timing calibration can be tested by turning the timing calibration on and off via the “Apply Timing Calibration” check box.

Waveforms can be saved in ASCII and binary formats by pressing the “Save” button. After opening a file, each trigger will write the waveform of the active channel(s) to that file. Note that when running for some time, the file will grow very quickly. If the file has the extension “.xml” it will be written in ASCII form using XML encoding, otherwise a raw binary file will be written. Here is a snippet of such an XML file:

```
<?xml version="1.0" encoding="ISO-8859-1"?>
<!-- created by MXML on Fri Dec 13 16:11:35 2013 -->
<DRSOSC>
  <Event>
    <Serial>1</Serial>
    <Time>2013/12/13 16:11:35.341</Time>
    <HUnit>ns</HUnit>
    <VUnit>mV</VUnit>
    <Board_2345>
      <Trigger_Cell>121</Trigger_Cell>
      <Scaler1>1234</Scaler1>
      <CHN1>
        <Data>-1.546,-472.3</Data>
        <Data>-1.320,-428.3</Data>
        ...
        <Data>198.020,-499.9</Data>
        <Data>198.267,-475.3</Data>
        </Data>
      <Scaler2>1234</Scaler2>
      <CHN2>
        <Data>-1.568,-439.0</Data>
        <Data>-1.335,-388.7</Data>
        ...
        <Data>198.000,-481.6</Data>
        <Data>198.261,-448.3</Data>
      </CHN2>
    </Board_2345>
  </Event>
  <Event>
    <Serial>2</Serial>
    <Time>2013/12/13 16:11:35.343</Time>
    <HUnit>ns</HUnit>
    <VUnit>mV</VUnit>
    <Board_2345>
      <Trigger_Cell>101</Trigger_Cell>
      <Scaler1>4321</Scaler1>
      <CHN1>
        <Data>-1.653,-516.0</Data>
        <Data>-1.437,-462.9</Data>
        ...
      </CHN1>
    </Board_2345>
  </Event>
</DRSOSC>
```

Each individual event contains a header with the serial number of that event (starting with 1), and the date/time it has been recorded. This is followed by the evaluation board serial number. In case of a multi-board configuration (starting with software version 4.1) there might be more than one board recorded, which can be distinguished by their board serial numbers. After the board serial number there is an entry of the Trigger Cell. This is the DRS4 memory cell which received the trigger, which can normally be ignored.

Then there is the channel data with pairs of time (in ns) and voltage (in mV), where time zero is at the trigger point. The number of channels depend on which channel was on when the

data was recorded. It might be a single channel (CHN1) or all four channels (CHN1-CHN4). Please note that the XML format requires more hard disk space compared to the binary format and takes also more CPU power to be written, so the maximum data rate is limited.

The binary format requires less space and can be written faster, but it requires a special program to read and analyze the data afterwards.

Depending on the number of channels that are “on” during data acquisition, the file contains up to four channels for each evaluation board, which can be identified by their channel headers. In a multi-board setup (starting with software version 4.1) there can be more than one board per event. In this case there are several board blocks with different board serial numbers.

At the beginning of each file there is a section that contains the timing calibration of one or more boards. In the DRS4 chip, the “width” of each sampling bin is different, and therefore needs to be measured and calibrated. This timing calibration is stored inside the EEPROM of each evaluation board. The timing section at the beginning of the binary file contains a copy of this timing calibration. Since it is constant over time, it is valid for all events in the file and is not repeated for each event in order to save space. Starting with the V5 board, each channel has its own calibration. Depending which channels were turned on during acquisition, there might be 1-4 timing calibration arrays, which can be seen from the channel headers.

One problem however is that in each event the readout starts at a different position of the DRS4 chip (the so-called “trigger cell”). Unlike in the XML format, the voltage/time pairs have to be calculated for each event individually. If the array $dt_{ch}[1024]$ contains the effective bin widths of a channel ch of the DRS4 chip obtained from the binary file, the time $t_{ch}[i]$ belonging to sample i can be calculated using the trigger cell t_{cell} as follows:

$$t_{ch}[i] = \sum_{j=0}^{i-1} dt_{ch}[(j + t_{cell})\%1024]$$

where % is the modulo operator. The time array starts with $t_{ch}[0]=0$.

Another complication comes from the fact that the timing of the channels in a DRS chip is different. So a given cell i has a different absolute time in each channel. The only common point in time is cell #0 (the first cell in the capacitor array), which has the same absolute time in all DRS channels. To obtain best timing, it is therefore necessary to align all channels such that their cell #0 has the same time $t_{ch,0}$ as given by

$$t_{ch,0} = t_{ch}[(1024 - t_{cell})\%1024]$$

If channel 1 is used as the reference point, the time arrays of the other channels can be shifted so that their cell #0 aligns:

$$t_{ch}[i]^{corrected} = t_{ch}[i] - (t_{ch,0} - t_{0,0})$$

The distribution contains a file `read_binary.cpp`, which reads the binary data format produced by `DRSOsc` and calculates the correct times as described above. It can be used as an example program to analyze binary waveform data.

The timing calibration section is followed by the actual waveform data. Each event can be identified by the event header ‘EHDR’, which is followed by one or more arrays of sampling values, depending on what channel was enabled during the acquisition. The voltage values are encoded as 2-byte integers, where 0 corresponds to -0.5V and 65535 corresponds to +0.5V.

All multi-byte data is encoded with LSB first, as in all Intel PC systems.

Word	Byte 0	Byte 1	Byte 2	Byte 3	Contents
0	'D'	'R'	'S'	'2'	File header, Byte 3 = version
1	'T'	'I'	'M'	'E'	Time Header
2	'B'	'#'	Board number		Board serial number
3	'C'	'0'	'0'	'1'	Channel 1 header
4	Time Bin Width #0				Effective time bin width in ns for channel 1 encoded in 4-Byte floating point format
5	Time Bin Width #1				
...	...				
1027	Time Bin Width #1023				
1028	'C'	'0'	'0'	'2'	Channel 2 header
1029	Time Bin Width #0				Effective time bin width in ns for channel 2 encoded in 4-Byte floating point format
1030	Time Bin Width #1				
...	...				
2052	Time Bin Width #1023				
2053	'E'	'H'	'D'	'R'	Event Header
2054	Event Serial Number				Serial number starting with 1
2055	Year		Month		Event date/time 16-bit values
2056	Day		Hour		
2057	Minute		Second		
2058	Millisecond		Range		
2059	'B'	'#'	Board number		Board serial number
2060	'T'	'#'	Trigger cell		Number of first readout cell
2061	'C'	'0'	'0'	'1'	Channel 1 header
2062	Scaler #1				Scaler for channel 1 in Hz
2063	Voltage Bin #0		Voltage Bin #1		Channel 1 waveform data encoded in 2-Byte integers. 0=RC-0.5V and 65535=RC+0.5V. RC see header.
2064	Voltage Bin #2		Voltage Bin #3		
...		
2574	Voltage Bin #1022		Voltage Bin #1023		
2575	'C'	'0'	'0'	'2'	Channel 2 header
2576	Scaler #2				Scaler for channel 2 in Hz
2577	Voltage Bin #0		Voltage Bin #1		Channel 2 waveform data encoded in 2-Byte integers. 0=RC-0.5V and 65535=RC+0.5V. RC see header.
2578	Voltage Bin #2		Voltage Bin #3		
...		
3088	Voltage Bin #1022		Voltage Bin #1023		
3089	'E'	'H'	'D'	'R'	Next Event Header
...					

Example of a binary file with two out of four channels being switched on.

3.3. Multi-board configuration

Starting with software version 4.1, multi-board setups are possible. Several evaluation boards might be connected simultaneously to a computer. On each event, all boards are read out together, which allows the setup of a small DAQ system with more than four input channels. The boards can be connected to individual PC USB ports, or an external USB hub can be used. Please make sure that the USB hub is externally powered, since each board draws 2.5 Watts, which cannot be satisfied by passive USB hubs. In multi-board configurations, the evaluation board with the highest serial number becomes the master board, and all other boards are treated as slave boards with descending serial numbers. Both the trigger and the clock (reference clock for the DRS4 chip) is passed in a daisy-chain mode from the master board via the Trigger OUT and Clock OUT connectors to the Trigger IN and Clock IN connectors of the first slave board and so on as depicted in the following figure:

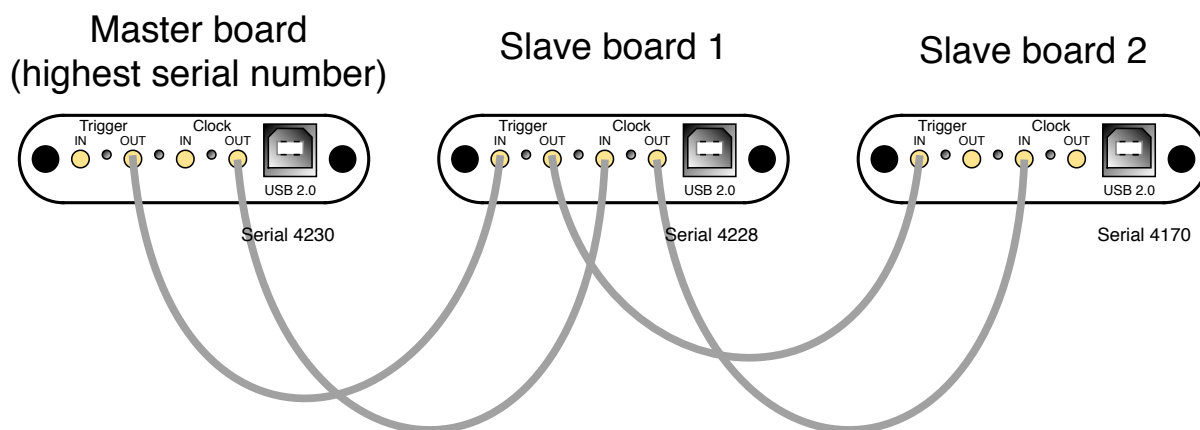

In this way, up to 16 boards can be connected. The trigger of the master board can be configured in the usual way, so it can trigger on an individual channel, a logic combination of its four channels, or it can trigger on the external input via Trigger IN. The slave boards receive then the trigger from the master board. A trigger logic incorporating the inputs of the slave boards however is not possible.

When using multi-board configurations, the maximum event rate is slower than for a single board, because all boards can only be read out one after the other. So the event rate drops to about 500 Hz / number of boards. In order to distinguish data from different boards, the board serial number is written into each event when writing to a XML or binary file (see previous section).

The timing between boards is poorer than between channels of the same board, which comes from the fact that the clock distribution causes some jitter when going through two FPGAs. A typical time resolution between two boards is 60 ps at 5 GSPS when using the clock distribution, and 400 ps when no clock distribution is used. The additional trigger delay between two boards is about 16 ns, then means slave board 1 triggers 16 ns after the master board, slave board 2 32 ns after the master board and so on. When building dedicated DRS4 boards, jitter-cleaner chips and differential clock distribution schemes can be used to keep the time resolution between boards also below 10 ps.

To configure a multi-board system, first connect the boards in the daisy-chain mode as shown above using MCX cables, and connect the USB cables. Then select “Configure multi-board daisy-chain” in the “Config” page of the DRSOsc program. The boards will then be configured correctly (like the trigger and reference clock of all slave boards will be set to “external”) and read out in sequence. When clicking on the “split-mode display” filed (cross hair button on the top right corner of the oscilloscope), the waveforms of all connected boards will be shown simultaneously:

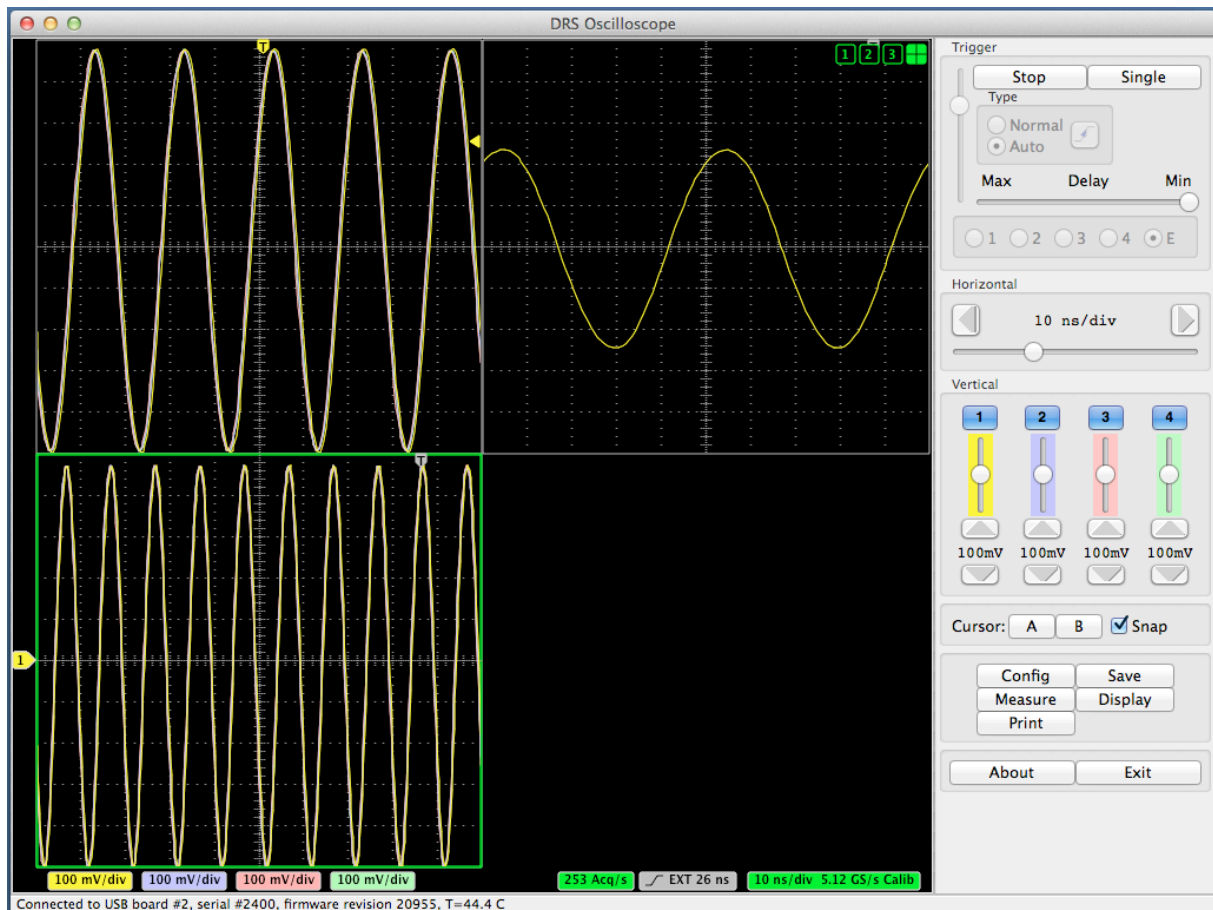

4. Development Hints

The idea behind the evaluation board is to make first steps in using the DRS4 chip, but then develop your own custom electronics around the chip. The first thing to do there is to study carefully the DRS4 data sheet, which can be obtained from <http://drs.web.psi.ch/datasheets>. Then have a look at the DRS4 Evaluation Board Reference Design, which schematics is supplied at the end of this document. When you start to design your own electronics, there are however some important points, which are not necessarily obvious from the data sheet or from the reference design. These points together with some design tips are explained in this section.

4.1. Power Supply

As with any analog design, the quality of the power supply is very important, since it has an influence of the noise level measured by the DRS4 chip. Low noise linear regulators together with the usual decoupling capacitors are recommended for all power supplies. The analog

power supply AV_{DD} powers only the domino circuit of the DRS4 chip and directly influences the jitter of the sampling frequency. Long term variations in this power supply (seconds...) are regulated by the on-chip PLL, but high frequency noise in the MHz region leads directly to an increase of the PLL jitter. Therefore the evaluation board contains two separate 2.5V linear regulators for the DRS4 chip, one for the AV_{DD} power and one for the DV_{DD} power. Although the DV_{DD} power is called “digital power”, it powers also the analog output buffers of the DRS4 chip and needs the same good quality than the AV_{DD} power in order to minimize the noise of the board.

The DRS4 chip also contains two grounds AGND and DGND. They can be either routed separately on the board and be connected at the power source, or they can be directly connected to an overall dedicated ground plane of the PCB. Tests have been shown that the latter choice gives slightly less noise.

The bottom of the QFN76 package of the DRS4 has an exposed paddle connected to the internal DGND. It is recommended that this paddle is matched by a PCB pad of similar size connected to analog ground to achieve the best electrical and thermal performance of the DRS4. The copper plane should have several vias to achieve a good heat dissipation to flow through the PCB as shown in Figure 3:

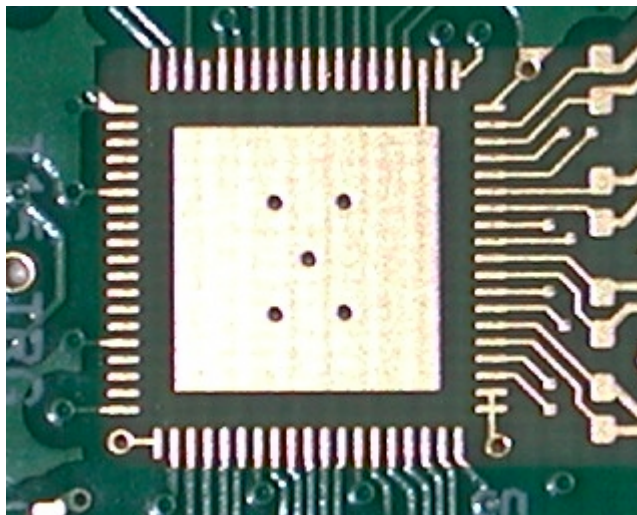

Figure 3: PCB pad under the DRS4 chip

These vias should be solder-filled or plugged. The maximum power dissipation of the DRS4 chip is not critical (350 mW), but an improved thermal stability helps the performance of any analog chip. To maximize the coverage and adhesion between the DRS4 and the PCB, the copper plane could be partitioned into several uniform sections, providing several tie points during the reflow process.

4.2. Analog Input

If non-differential signals should be digitized with the DRS4 chip, they must be converted into differential signals for the DRS4 inputs. The simplest solution is to connect the IN- inputs to AGND and to connect the signals directly to the IN+ inputs. This method has however the disadvantage that the crosstalk and noise immunity of the DRS4 chip are worsened. The evaluation board V3 uses differential drivers THS4508 from Texas Instruments® for this purpose. These drivers were carefully selected since they have to drive the relatively high DRS4 input current of almost 1 mA and capacitive load without compromising the analog bandwidth. The current design gives about 700 MHz (-3 dB) with moderate power consumption, so that the evaluation board can still be powered from the USB power (500 mA

@ 5V). The linear regulator of the evaluation board V2 could however not be used, since the efficiency would be too low. Instead, a switching regulator LMZ10503 from National Semiconductor[®] is used on the board. It has an efficiency of more than 95% and a low output ripple. The output voltage of 3.3V is then converted using traditional linear regulators into two 2.5V low noise power supplies, which power the analog part of the board.

Other designs are possible which push the analog bandwidth to 800 or 900 MHz, close to the theoretical limit of 950 MHz of the DRS4 chip, but they require more power.

The usual design rules like proper termination, matched impedance PCB traces and separate power supply PCB planes apply as in any high frequency analog design.

4.3. Control Voltages

The DRS4 chip requires certain control voltages: ROFS, O-OFS and BIAS. The latter two are generated internally with some default voltage, but can be “overwritten” by an external low impedance source. It is recommended to connect these lines to an external 16-bit DAC, so that the DRS4 input range can be fine-tuned on a board-by-board basis, to compensate for chip variations. The ROFS signal should be driven by a high speed low noise buffer. If this signal would be directly connected to the DAC output, the signal height would change slightly during the chip readout and the measurement would show a varying baseline level.

4.4. ADC Clock

There is a very strict relation between the DRS4 output shift register clock SRCLK and the ADC clock (see DRS4 data sheet WAVEFORM READOUT). In order to reduce the noise due to aperture jitter, the phase shift between these two clocks must be fixed and contain very small jitter (~10ps). The easiest way to generate this phase shift is to use the digital clock managers (DCM) in the FPGA, as it is done on the evaluation board. Since the DCMs have however an inherent phase jitter of up to 150ps, this introduces some noise in form of a baseline variation when sampling a DC signal in the order of up to a few mV. If this becomes a problem, it is recommended to generate the phase shift between these two clocks with a low jitter delay circuit.

4.5. Calibration

In order to perform a proper voltage calibration of the DRS4 chip, a well-defined DC voltage needs to be connected to all DRS4 inputs and measured. The evaluation board uses the on-board 16-bit DAC connected to all inputs for that purpose. Since the DRS4 chip draws quite some current on its inputs, the DAC is buffered via a low noise OpAmp AD8605.

For the timing calibration, a low jitter 100 MHz sine wave needs to be connected to all channels. In evaluation boards previous to version 5, only one DRS4 channel was connected to the clock, which allows timing calibrations good for about 10-15 ps. To achieve the ultimate resolution below 3 ps, the clock needs to be connected to all DRS4 channels via analog switches. The sine wave is obtained from a low jitter quartz oscillator with a passive 3rd order low pass filter. Since the oscillator would cause some noise during normal operation, it can be disabled through the FPGA.

5. DRS4 Evaluation Board V5 Schematics

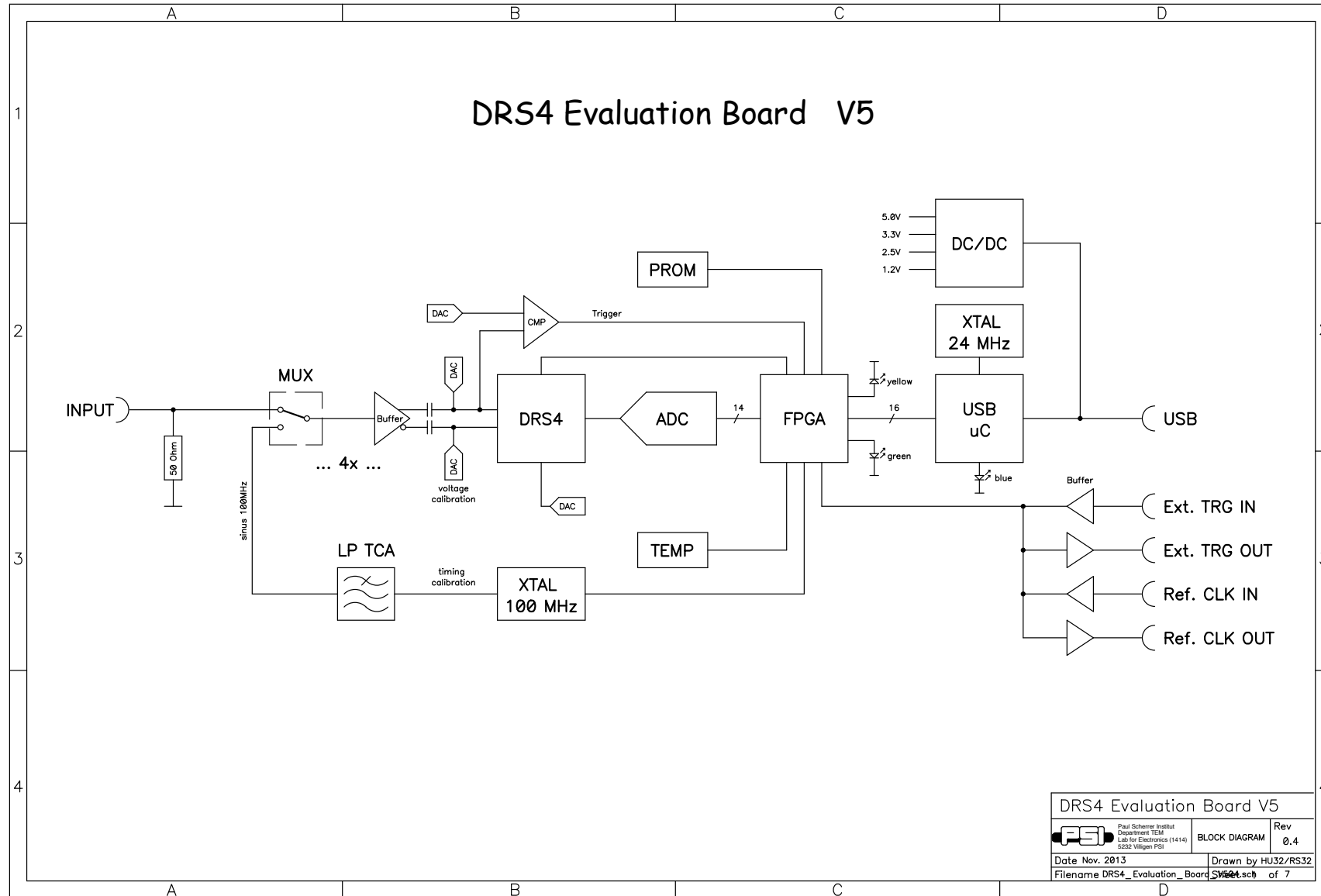

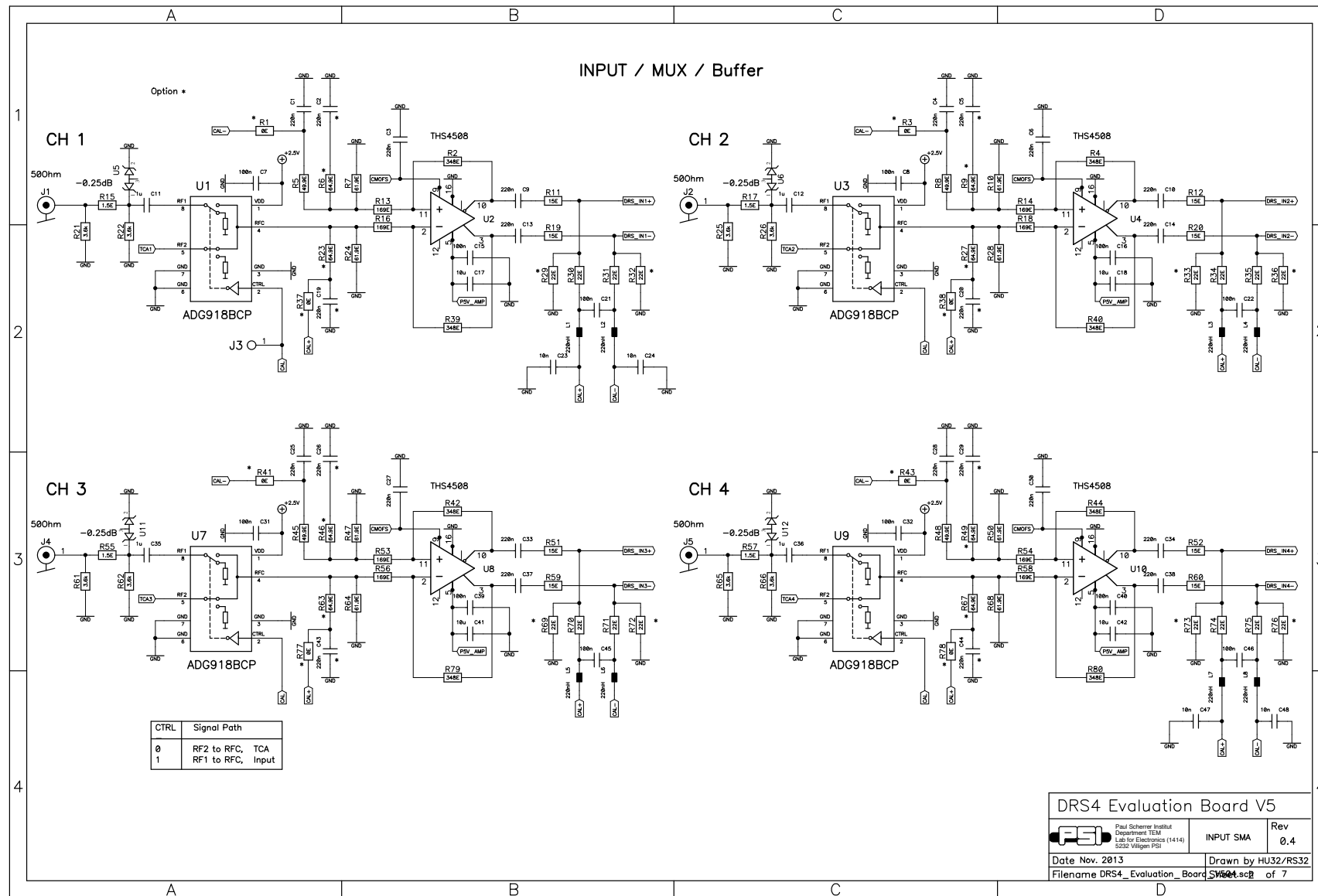

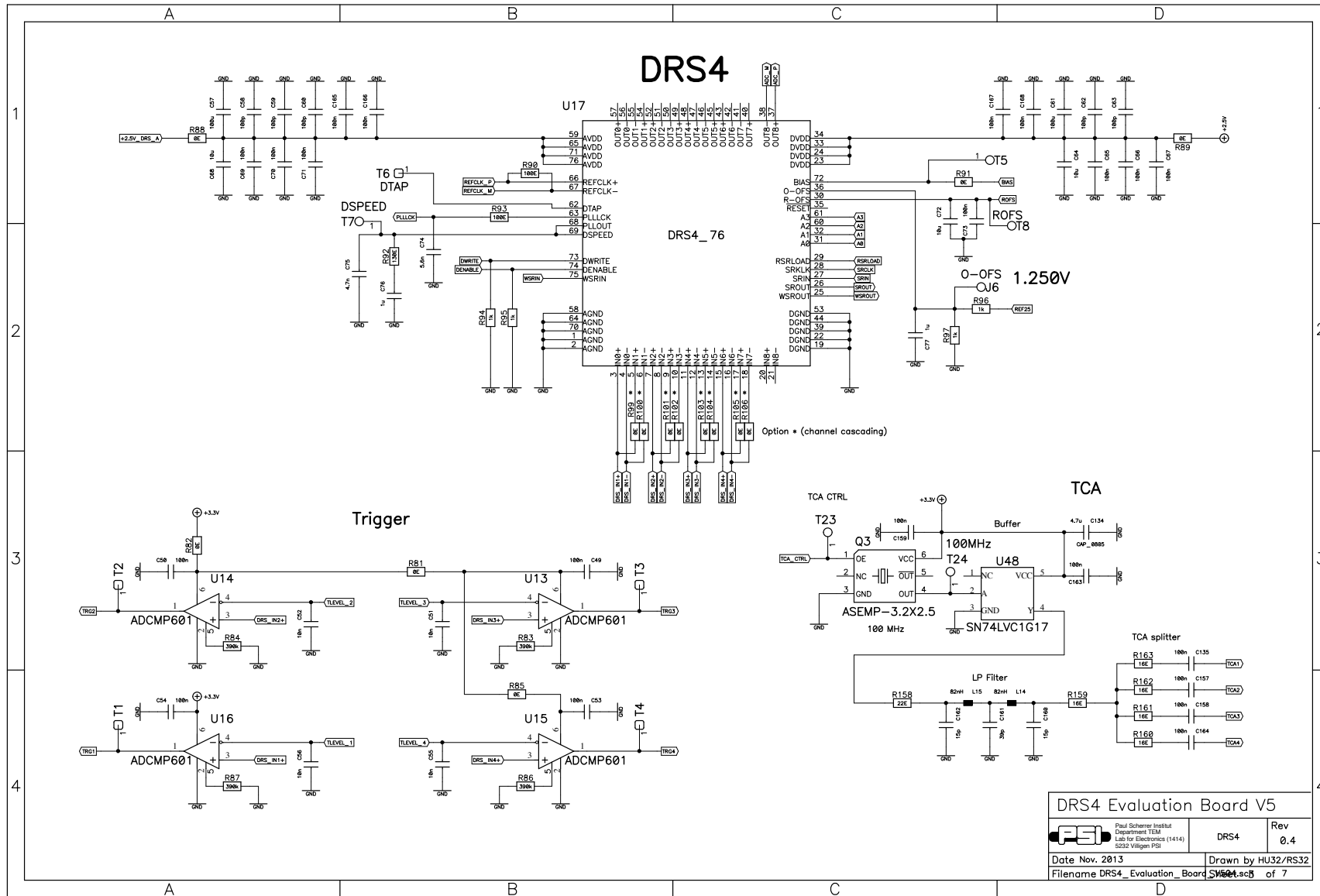

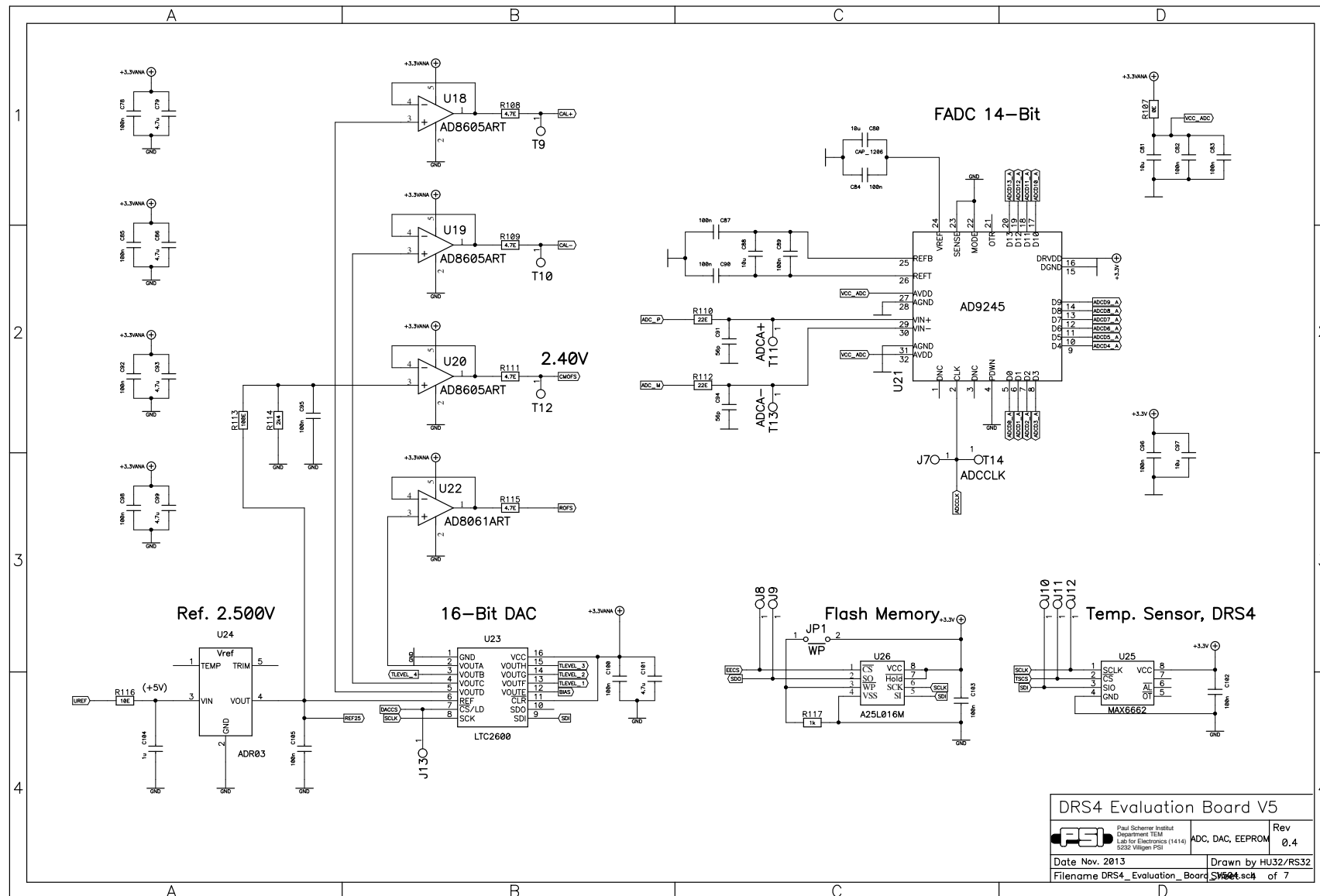

DRS4 Evaluation Board V5		Rev	
 Paul Scherrer Institut Department TEM Lab for Electronics (14.14) 5232 Wilgen PSI		ADC, DAC, EEPROM	0.4
Date Nov. 2013		Drawn by HU32/RS32	
Filename DRS4_Evaluation_Board V504.sch		Sheet 4 of 7	

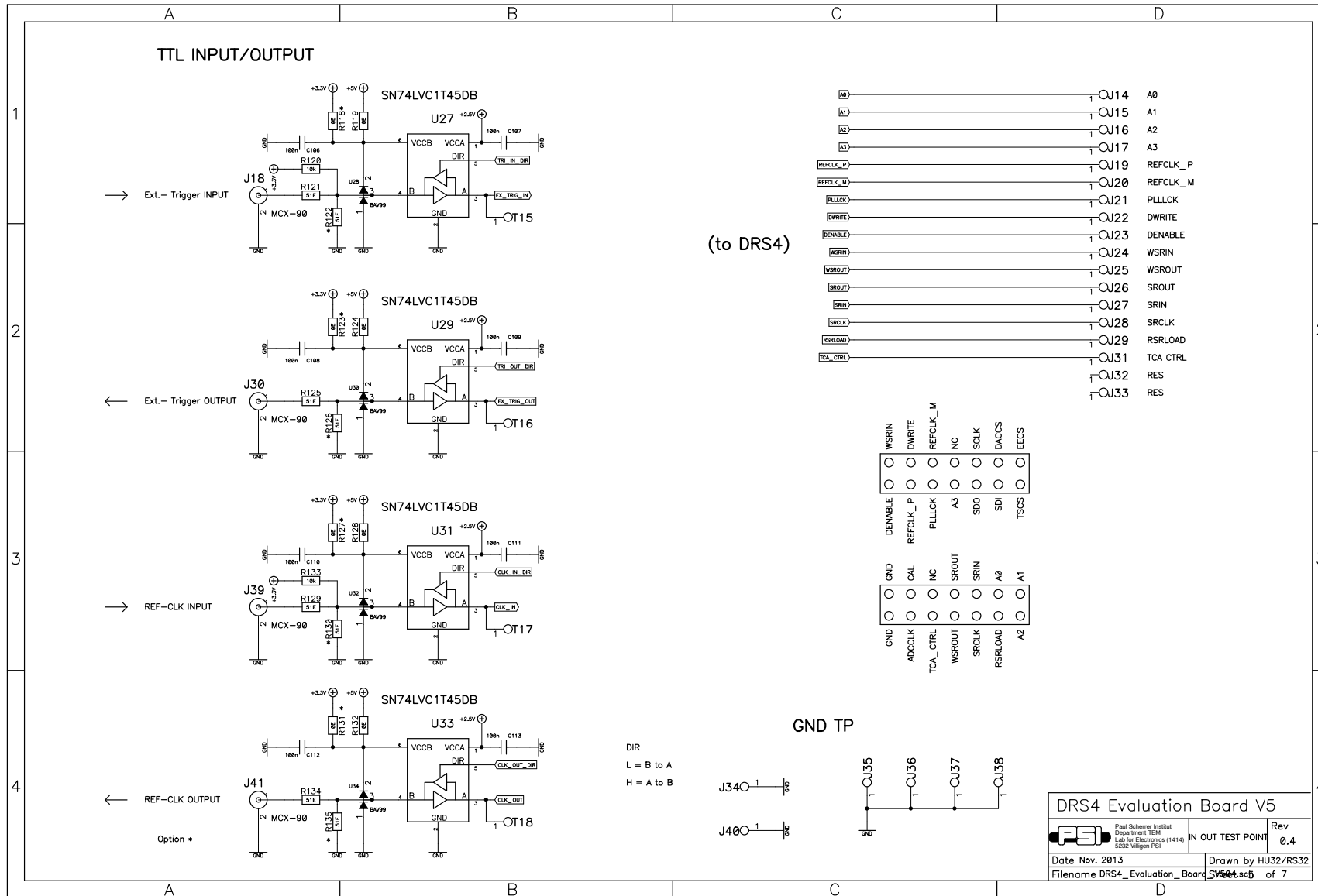

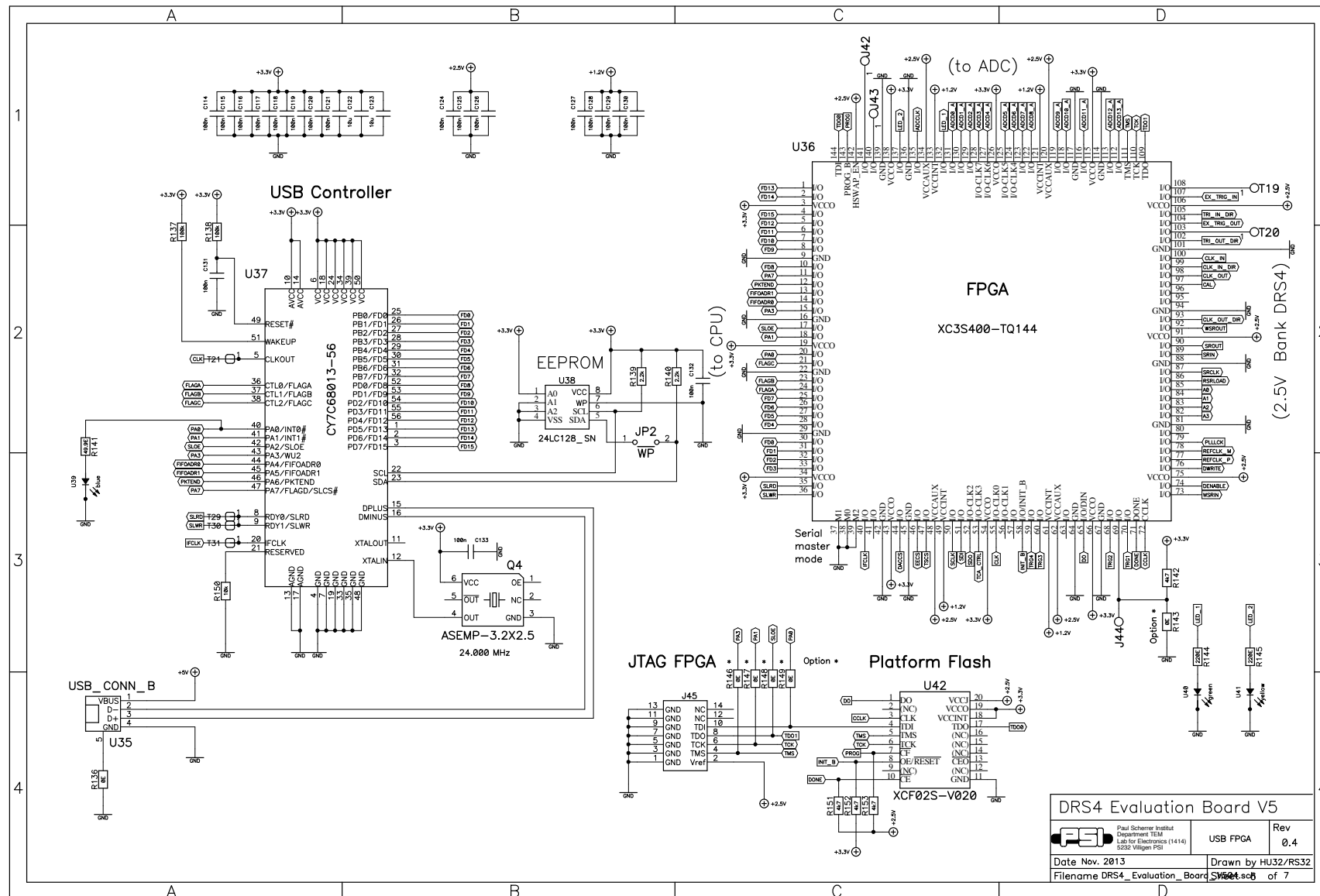

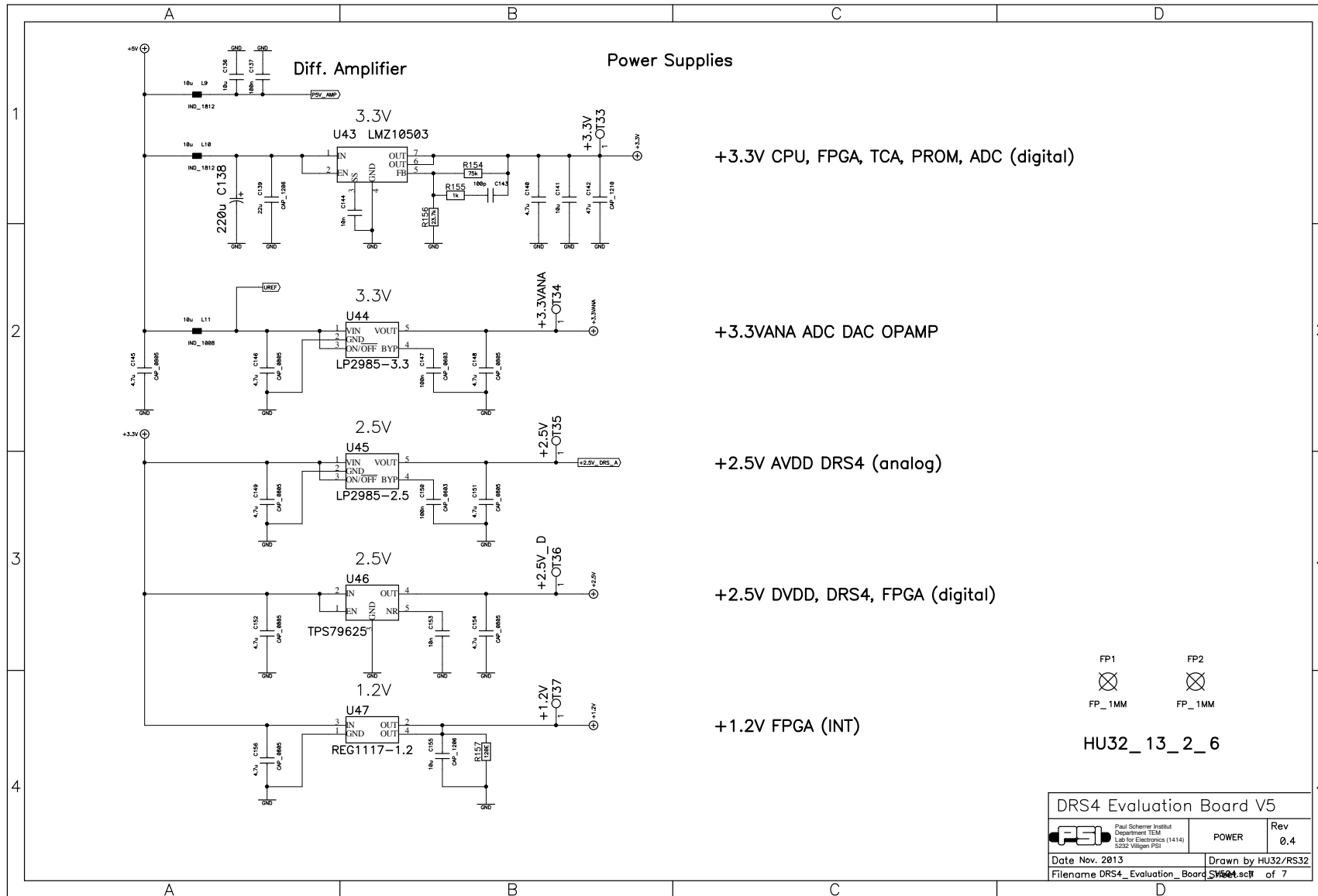

6. DRS4 Evaluation Board V5 Bill of Materials

Count	Name	RefDes	Pattern	Value	Description
1	24LC128_SN	U38	SO-G8		Serial EEPROM
1	A25L016M	U26	SO-8-SM		Serial Flash Memory
1	AD8061ART	U22	SOT23-5		300MHz Voltage Feedback Amplifier
3	AD8605ART	U18	SOT23-5		300MHz Voltage Feedback Amplifier
	AD8605ART	U19	SOT23-5		300MHz Voltage Feedback Amplifier
	AD8605ART	U20	SOT23-5		300MHz Voltage Feedback Amplifier
1	AD9245	U21	LFCSP_VQ_32		14-bit ADC
4	ADCM601	U13	SC70-6		Fast comparator
	ADCM601	U14	SC70-6		Fast comparator
	ADCM601	U15	SC70-6		Fast comparator
	ADCM601	U16	SC70-6		Fast comparator
4	ADG918BCP	U1	CP-8-2		Wideband analog switch
	ADG918BCP	U3	CP-8-2		Wideband analog switch
	ADG918BCP	U7	CP-8-2		Wideband analog switch
	ADG918BCP	U9	CP-8-2		Wideband analog switch
1	ADR03	U24	SC70-5		2.5V Precision voltage reference
1	ASEMP-3.2X2.5	Q4		24.000 MHz	Clock oscillator
1	ASEMP-3.2X2.5	Q3		100 MHz	Clock oscillator
4	BAV99	U28	SOT23-3		High speed double diode
	BAV99	U30	SOT23-3		High speed double diode
	BAV99	U32	SOT23-3		High speed double diode
	BAV99	U34	SOT23-3		High speed double diode
1	CAPP	C138	CAPP	220u	
4	CAP_0402	C51		402 10n	
	CAP_0402	C52		402 10n	
	CAP_0402	C55		402 10n	
	CAP_0402	C56		402 10n	
23	CAP_0402	C7		402 100n	
	CAP_0402	C8		402 100n	
	CAP_0402	C15		402 100n	
	CAP_0402	C16		402 100n	
	CAP_0402	C21		402 100n	
	CAP_0402	C22		402 100n	
	CAP_0402	C31		402 100n	
	CAP_0402	C32		402 100n	
	CAP_0402	C39		402 100n	
	CAP_0402	C40		402 100n	
	CAP_0402	C45		402 100n	
	CAP_0402	C46		402 100n	
	CAP_0402	C49		402 100n	
	CAP_0402	C50		402 100n	
	CAP_0402	C53		402 100n	
	CAP_0402	C135		402 100n	
	CAP_0402	C157		402 100n	
	CAP_0402	C158		402 100n	
	CAP_0402	C164		402 100n	
	CAP_0402	C165		402 100n	
	CAP_0402	C166		402 100n	
	CAP_0402	C167		402 100n	
	CAP_0402	C168		402 100n	
5	CAP_0402	C58		402 100p	
	CAP_0402	C59		402 100p	
	CAP_0402	C60		402 100p	
	CAP_0402	C62		402 100p	
	CAP_0402	C63		402 100p	
24	CAP_0402	C1		402 220n	
	CAP_0402	C2		402 220n	

DRS4 Evaluation Board User's Manual

	CAP_0402	C3	402	220n
	CAP_0402	C4	402	220n
	CAP_0402	C5	402	220n
	CAP_0402	C6	402	220n
	CAP_0402	C9	402	220n
	CAP_0402	C10	402	220n
	CAP_0402	C13	402	220n
	CAP_0402	C14	402	220n
	CAP_0402	C19	402	220n
	CAP_0402	C20	402	220n
	CAP_0402	C25	402	220n
	CAP_0402	C26	402	220n
	CAP_0402	C27	402	220n
	CAP_0402	C28	402	220n
	CAP_0402	C29	402	220n
	CAP_0402	C30	402	220n
	CAP_0402	C33	402	220n
	CAP_0402	C34	402	220n
	CAP_0402	C37	402	220n
	CAP_0402	C38	402	220n
	CAP_0402	C43	402	220n
	CAP_0402	C44	402	220n
7	CAP_0603	C11	603	1u
	CAP_0603	C12	603	1u
	CAP_0603	C35	603	1u
	CAP_0603	C36	603	1u
	CAP_0603	C76	603	1u
	CAP_0603	C77	603	1u
	CAP_0603	C104	603	1u
1	CAP_0603	C75	603	4.7n
1	CAP_0603	C74	603	5.6n
6	CAP_0603	C23	603	10n
	CAP_0603	C24	603	10n
	CAP_0603	C47	603	10n
	CAP_0603	C48	603	10n
	CAP_0603	C144	603	10n
	CAP_0603	C153	603	10n
2	CAP_0603	C160	603	15p
	CAP_0603	C162	603	15p
1	CAP_0603	C161	603	39p
2	CAP_0603	C91	603	56p
	CAP_0603	C94	603	56p
54	CAP_0603	C54	603	100n
	CAP_0603	C65	603	100n
	CAP_0603	C66	603	100n
	CAP_0603	C67	603	100n
	CAP_0603	C69	603	100n
	CAP_0603	C70	603	100n
	CAP_0603	C71	603	100n
	CAP_0603	C73	603	100n
	CAP_0603	C78	603	100n
	CAP_0603	C82	603	100n
	CAP_0603	C83	603	100n
	CAP_0603	C84	603	100n
	CAP_0603	C85	603	100n
	CAP_0603	C87	603	100n
	CAP_0603	C89	603	100n
	CAP_0603	C90	603	100n
	CAP_0603	C92	603	100n
	CAP_0603	C95	603	100n
	CAP_0603	C96	603	100n

	CAP_0603	C98	603	100n
	CAP_0603	C100	603	100n
	CAP_0603	C102	603	100n
	CAP_0603	C103	603	100n
	CAP_0603	C105	603	100n
	CAP_0603	C106	603	100n
	CAP_0603	C107	603	100n
	CAP_0603	C108	603	100n
	CAP_0603	C109	603	100n
	CAP_0603	C110	603	100n
	CAP_0603	C111	603	100n
	CAP_0603	C112	603	100n
	CAP_0603	C113	603	100n
	CAP_0603	C114	603	100n
	CAP_0603	C115	603	100n
	CAP_0603	C116	603	100n
	CAP_0603	C117	603	100n
	CAP_0603	C118	603	100n
	CAP_0603	C119	603	100n
	CAP_0603	C120	603	100n
	CAP_0603	C121	603	100n
	CAP_0603	C124	603	100n
	CAP_0603	C125	603	100n
	CAP_0603	C126	603	100n
	CAP_0603	C127	603	100n
	CAP_0603	C128	603	100n
	CAP_0603	C129	603	100n
	CAP_0603	C130	603	100n
	CAP_0603	C132	603	100n
	CAP_0603	C133	603	100n
	CAP_0603	C137	603	100n
	CAP_0603	C147	603	100n
	CAP_0603	C150	603	100n
	CAP_0603	C159	603	100n
	CAP_0603	C163	603	100n
1	CAP_0603	C143	603	100p
15	CAP_0805	C79	805	4.7u
	CAP_0805	C86	805	4.7u
	CAP_0805	C93	805	4.7u
	CAP_0805	C99	805	4.7u
	CAP_0805	C101	805	4.7u
	CAP_0805	C134	805	4.7u
	CAP_0805	C140	805	4.7u
	CAP_0805	C145	805	4.7u
	CAP_0805	C146	805	4.7u
	CAP_0805	C148	805	4.7u
	CAP_0805	C149	805	4.7u
	CAP_0805	C151	805	4.7u
	CAP_0805	C152	805	4.7u
	CAP_0805	C154	805	4.7u
	CAP_0805	C156	805	4.7u
16	CAP_1206	C17	1206	10u
	CAP_1206	C18	1206	10u
	CAP_1206	C41	1206	10u
	CAP_1206	C42	1206	10u
	CAP_1206	C64	1206	10u
	CAP_1206	C68	1206	10u
	CAP_1206	C72	1206	10u
	CAP_1206	C80	1206	10u
	CAP_1206	C81	1206	10u
	CAP_1206	C88	1206	10u

DRS4 Evaluation Board User's Manual

	CAP_1206	C97	1206	10u	
	CAP_1206	C122	1206	10u	
	CAP_1206	C123	1206	10u	
	CAP_1206	C136	1206	10u	
	CAP_1206	C141	1206	10u	
	CAP_1206	C155	1206	10u	
1	CAP_1206	C139	1206	22u	
1	CAP_1206	C131	1206	100n	
1	CAP_1210	C142	1210	47u	
2	CAP_1210	C57	1210	100u	
	CAP_1210	C61	1210	100u	
1	CONN_MOLEX_J	J45	DIL14P_2MM	JTAG	
1	CY7C68013-56	U37	SSO-G56		USB microcontroller
1	DRS4_76	U17	QFN-76		Domino Ring Sampling Chip V4
2	FP_1MM	FP1	FP_1MM		
	FP_1MM	FP2	FP_1MM		
2	IND_0603	L14	603	82nH	
	IND_0603	L15	603	82nH	
8	IND_0603	L1	603	220nH	
	IND_0603	L2	603	220nH	
	IND_0603	L3	603	220nH	
	IND_0603	L4	603	220nH	
	IND_0603	L5	603	220nH	
	IND_0603	L6	603	220nH	
	IND_0603	L7	603	220nH	
	IND_0603	L8	603	220nH	
1	IND_1008	L11	1008	10u	
2	IND_1812	L9	1812	10u	
	IND_1812	L10	1812	10u	
2	JMP2MM	JP1	TP50MIL	~WP	Jumper
	JMP2MM	JP2	TP50MIL	~WP	Jumper
1	LED_PLCC-4	U39	PLCC-4	blue	LED
1	LED_PLCC-4	U40	PLCC-4	green	LED
1	LED_PLCC-4	U41	PLCC-4	yellow	LED
1	LMZ10503	U43	TO-PMOD-7		800mA and 1A Low Dropout Positive Regulator 2.85V,
1	LP2985-2.5	U45	SOT23-5		800mA and 1A Low Dropout Positive Regulator 2.85V,
1	LP2985-3.3	U44	SOT23-5		800mA and 1A Low Dropout Positive Regulator 2.85V,
1	LTC2600	U23	SSOP16		16-bit octal DAC
1	MAX6662	U25	SO-G8		SPI Temperature Sensor
4	MCX-90	J18	MCX-90		MCX connector 90 deg.
	MCX-90	J30	MCX-90		MCX connector 90 deg.
	MCX-90	J39	MCX-90		MCX connector 90 deg.
	MCX-90	J41	MCX-90		MCX connector 90 deg.
4	RCLAMP0502B	U5	SOT523		Protection diode
	RCLAMP0502B	U6	SOT523		Protection diode
	RCLAMP0502B	U11	SOT523		Protection diode
	RCLAMP0502B	U12	SOT523		Protection diode
1	REG1117-1.2	U47	SOT223		800mA and 1A Low Dropout Positive Regulator 2.85V,
19	RES_0402	R1		402	0E
	RES_0402	R3		402	0E
	RES_0402	R37		402	0E
	RES_0402	R38		402	0E
	RES_0402	R41		402	0E
	RES_0402	R43		402	0E
	RES_0402	R77		402	0E
	RES_0402	R78		402	0E
	RES_0402	R99		402	0E
	RES_0402	R100		402	0E
	RES_0402	R101		402	0E
	RES_0402	R102		402	0E
	RES_0402	R103		402	0E

	RES_0402	R104	402	0E
	RES_0402	R105	402	0E
	RES_0402	R106	402	0E
	RES_0402	R146	402	0E
	RES_0402	R147	402	0E
	RES_0402	R148	402	0E
8	RES_0402	R11	402	15E
	RES_0402	R12	402	15E
	RES_0402	R19	402	15E
	RES_0402	R20	402	15E
	RES_0402	R51	402	15E
	RES_0402	R52	402	15E
	RES_0402	R59	402	15E
	RES_0402	R60	402	15E
5	RES_0402	R159	402	16E
	RES_0402	R160	402	16E
	RES_0402	R161	402	16E
	RES_0402	R162	402	16E
	RES_0402	R163	402	16E
16	RES_0402	R29	402	22E
	RES_0402	R30	402	22E
	RES_0402	R31	402	22E
	RES_0402	R32	402	22E
	RES_0402	R33	402	22E
	RES_0402	R34	402	22E
	RES_0402	R35	402	22E
	RES_0402	R36	402	22E
	RES_0402	R69	402	22E
	RES_0402	R70	402	22E
	RES_0402	R71	402	22E
	RES_0402	R72	402	22E
	RES_0402	R73	402	22E
	RES_0402	R74	402	22E
	RES_0402	R75	402	22E
	RES_0402	R76	402	22E
4	RES_0402	R5	402	49.9E
	RES_0402	R8	402	49.9E
	RES_0402	R45	402	49.9E
	RES_0402	R48	402	49.9E
8	RES_0402	R7	402	61.9E
	RES_0402	R10	402	61.9E
	RES_0402	R24	402	61.9E
	RES_0402	R28	402	61.9E
	RES_0402	R47	402	61.9E
	RES_0402	R50	402	61.9E
	RES_0402	R64	402	61.9E
	RES_0402	R68	402	61.9E
8	RES_0402	R6	402	64.9E
	RES_0402	R9	402	64.9E
	RES_0402	R23	402	64.9E
	RES_0402	R27	402	64.9E
	RES_0402	R46	402	64.9E
	RES_0402	R49	402	64.9E
	RES_0402	R63	402	64.9E
	RES_0402	R67	402	64.9E
2	RES_0402	R90	402	100E
	RES_0402	R93	402	100E
8	RES_0402	R13	402	169E
	RES_0402	R14	402	169E
	RES_0402	R16	402	169E
	RES_0402	R18	402	169E

DRS4 Evaluation Board User's Manual

	RES_0402	R53	402	169E
	RES_0402	R54	402	169E
	RES_0402	R56	402	169E
	RES_0402	R58	402	169E
8	RES_0402	R2	402	348E
	RES_0402	R4	402	348E
	RES_0402	R39	402	348E
	RES_0402	R40	402	348E
	RES_0402	R42	402	348E
	RES_0402	R44	402	348E
	RES_0402	R79	402	348E
	RES_0402	R80	402	348E
3	RES_0402	R83	402	390k
	RES_0402	R84	402	390k
	RES_0402	R86	402	390k
14	RES_0603	R81	603	0E
	RES_0603	R82	603	0E
	RES_0603	R85	603	0E
	RES_0603	R91	603	0E
	RES_0603	R118	603	0E
	RES_0603	R119	603	0E
	RES_0603	R123	603	0E
	RES_0603	R124	603	0E
	RES_0603	R127	603	0E
	RES_0603	R128	603	0E
	RES_0603	R131	603	0E
	RES_0603	R132	603	0E
	RES_0603	R143	603	0E
	RES_0603	R149	603	0E
5	RES_0603	R94	603	1k
	RES_0603	R95	603	1k
	RES_0603	R97	603	1k
	RES_0603	R117	603	1k
	RES_0603	R155	603	1k
4	RES_0603	R15	603	1.5E
	RES_0603	R17	603	1.5E
	RES_0603	R55	603	1.5E
	RES_0603	R57	603	1.5E
1	RES_0603	R114	603	2k4
2	RES_0603	R139	603	2.2k
	RES_0603	R140	603	2.2k
8	RES_0603	R21	603	3.6k
	RES_0603	R22	603	3.6k
	RES_0603	R25	603	3.6k
	RES_0603	R26	603	3.6k
	RES_0603	R61	603	3.6k
	RES_0603	R62	603	3.6k
	RES_0603	R65	603	3.6k
	RES_0603	R66	603	3.6k
3	RES_0603	R151	603	4k7
	RES_0603	R152	603	4k7
	RES_0603	R153	603	4k7
1	RES_0603	R142	603	4k7
4	RES_0603	R108	603	4.7E
	RES_0603	R109	603	4.7E
	RES_0603	R111	603	4.7E
	RES_0603	R115	603	4.7E
1	RES_0603	R116	603	10E
3	RES_0603	R120	603	10k
	RES_0603	R133	603	10k
	RES_0603	R150	603	10k

2	RES_0603	R110	603	22E	
	RES_0603	R112	603	22E	
1	RES_0603	R158	603	22E	
1	RES_0603	R156	603	23.7k	
1	RES_0603	R141	603	49.9E	
1	RES_0603	R154	603	75k	
1	RES_0603	R113	603	100E	
2	RES_0603	R137	603	100k	
	RES_0603	R138	603	100k	
1	RES_0603	R92	603	130E	
2	RES_0603	R144	603	220E	
	RES_0603	R145	603	220E	
1	RES_0603	R87	603	390k	
2	RES_0805	R88	805	0E	
	RES_0805	R89	805	0E	
2	RES_0805	R107	805	0E	
	RES_0805	R136	805	0E	
1	RES_0805	R96	805	1k	
8	RES_0805	R121	805	51E	
	RES_0805	R122	805	51E	
	RES_0805	R125	805	51E	
	RES_0805	R126	805	51E	
	RES_0805	R129	805	51E	
	RES_0805	R130	805	51E	
	RES_0805	R134	805	51E	
	RES_0805	R135	805	51E	
1	RES_1206	R157	1206	120E	
4	SMA_SMD_S	J1	SMA_SMD_S		SMA-Coaxial Connector, PCB right angle receptacle
	SMA_SMD_S	J2	SMA_SMD_S		SMA-Coaxial Connector, PCB right angle receptacle
	SMA_SMD_S	J4	SMA_SMD_S		SMA-Coaxial Connector, PCB right angle receptacle
	SMA_SMD_S	J5	SMA_SMD_S		SMA-Coaxial Connector, PCB right angle receptacle
1	SN74LVC1G17	U48	PDSO-G5		Dual Positive-Edge-Triggered D-Type Flip-Flop
4	SN74LVC1T45DB	U27	SOT23-6		
	SN74LVC1T45DB	U29	SOT23-6		
	SN74LVC1T45DB	U31	SOT23-6		
	SN74LVC1T45DB	U33	SOT23-6		
4	THS4508	U2	THS4509		Low noise differential amplifier
	THS4508	U4	THS4509		Low noise differential amplifier
	THS4508	U8	THS4509		Low noise differential amplifier
	THS4508	U10	THS4509		Low noise differential amplifier
1	TPS79625	U46	SOT223-5		800mA and 1A Low Dropout Positive Regulator 2.85V, 2.85V, 2.85V, 2.85V
1	USB_CONN_B	U35	USB_CONN_B		USB Connector
1	XC3S400-TQ144	U36	TQFP144		FPGA
1	XCF02S-V020	U42	TSSOP20		FPGA Flash PROM